

**Part # 42-02-1POO Rev. 1 Sept 2001**

**MOTION CONTROL ENGINEERING, INC.**  
11354 WHITE ROCK ROAD  
RANCHO CORDOVA, CA 95742  
TELEPHONE (916) 463-9200 FAX (916) 463-9201

## **CONTROLLER INSTALLATION MANUAL**

*HMC-1000 Series PHC*  
*Programmable Hydraulic Controller*



PART # 42-02-1P00 REV. G.1 SEPTEMBER 2001

## PTHC Programming Record

SalesOdr: <u>2002034100</u>	Job Name: <u>Cedar Brook Center</u>	Document # <u>090401H524</u>
PrdOdr: <u>3057360</u> Car:	Tech: <u>Chris</u>	PCA S/W Ver #: <u>05.24.0004</u>
Program: <u>Motion Control Engineering</u>	<u>Hydraulic Controller</u>	<input type="checkbox"/> EMI PA Ver#: <u>N/A</u>

### Basic Features

1. Simplex or Duplex ?
  - Simplex       Duplex       N/A for Simplex
2. Operation:
  - Selective Collective       N/A for Duplex
  - Single Button Collective
  - Single Automatic Push Button
3. Top Landing Served (This car)
 

2
4. Car Doors are Walk-Thru (This car)
  - Yes       No
5. Car Serves Front Floor (This car)?
  - 1  2  3  4  5  6  7  8  9  10  11  12  13  14  15  16  17
  - 18  19  20  21  22  23  24  25  26  27  28  29  30  31  32

Car Serves Rear Floor (This car)?

  - 01  02  03  04  05  06  07  08  09  10  11  12  13  14  15  16  17
  - 18  19  20  21  22  23  24  25  26  27  28  29  30  31  32
6. Top Landing Served Other Car?
  - N/A for Simplex
7. Other Cars Doors Walk-thru?
  - Yes       No       N/A for Simplex
8. Other Car Serves Front Floor?
  - 01  02  03  04  05  06  07  08  09  10  11  12  13  14  15  16  17
  - 18  19  20  21  22  23  24  25  26  27  28  29  30  31  32

Car Serves Rear Floor?

  - 01  02  03  04  05  06  07  08  09  10  11  12  13  14  15  16  17
  - 18  19  20  21  22  23  24  25  26  27  28  29  30  31  32
9. Parking Floor?
 

None
10. Secondary Park Floor?
  - N/A for Simplex or no Parking
11. Lobby Floor?
 

1
12. Car Identifier:
  - A       B       N/A for Simplex
13. Number of IOX Boards:
 

0
14. Number of I4O Boards:
 

1
15. Number of AIOX Boards:
 

0

### Fire Service

1. Fire Service Operation?
  - Yes       No
2. Fire Phase 1 Main Floor:
 

1

  - N/A if no Fire Service
3. Fire Phase 1 Alt. Floor:
 

2

  - N/A if no Fire Service
4. Fire Service Code:
 

ANSI 89 →

  - N/A if no Fire Service
5. Fire Phase 1, 2<sup>nd</sup> Alt. Floor:
 

  - N/A for non-Detroit Fire Code
6. Bypass Stop Sw. on Phase 1?
  - Yes       No
  - N/A if no Fire Service
7. Honeywell Fire Operation
  - Yes       No
  - N/A for non-Australia Fire Code
8. NYC Fire Phase 2 and ANSI 89?
  - Yes       No
  - N/A for non-ANSI 89 Fire Code
9. White Plains, NY Fire Code?
  - Yes       No
  - N/A for non-ANSI 89 Fire Code

**Door Operation**

ADA

- |                                     |  |  |   |
|-------------------------------------|--|--|---|
| 1. Nudging?                         | <input checked="" type="checkbox"/> Yes        | <input type="checkbox"/> No            |   |
| 2. Stuck Photo Eye Protection?      | <input checked="" type="checkbox"/> Yes        | <input type="checkbox"/> No            |   |
| 3. Sequential Door Operation (F/R)? | <input type="checkbox"/> Yes                   | <input type="checkbox"/> No            | <input checked="" type="checkbox"/> N/A if no walk through service  |
| 4. Car Call Cancels Door Time?      | <input type="checkbox"/> Yes                   | <input checked="" type="checkbox"/> No |   |
| 5. Nudging During Fire Phase 1?     | <input checked="" type="checkbox"/> Yes        | <input type="checkbox"/> No            | <input type="checkbox"/> N/A if no Fire Service   |
| 6. Retiring Cam Option?             | <input type="checkbox"/> Yes                   | <input checked="" type="checkbox"/> No |   |
| 7. Pre-Opening?                     | <input type="checkbox"/> Yes                   | <input checked="" type="checkbox"/> No |   |
| 8. Mechanical safety Edge?          | <input type="checkbox"/> Yes                   | <input checked="" type="checkbox"/> No |   |
| 9. Nudging Output/Buzzer Only?      | <input checked="" type="checkbox"/> Yes        | <input type="checkbox"/> No            |   |
| 10. D.C.B. Cancels Door Time?       | <input type="checkbox"/> Yes                   | <input checked="" type="checkbox"/> No |   |
| 11. Leave Door Open on PTI/ESS?     | <input type="checkbox"/> Yes                   | <input type="checkbox"/> No            | <input checked="" type="checkbox"/> N/A if no PTI or ESS input  |
| 12. Nudging During Fire Phase 2?    | <input type="checkbox"/> Yes                   | <input checked="" type="checkbox"/> No | <input type="checkbox"/> N/A if no Fire Service   |
| 13. Direction Preference Until DLK? | <input checked="" type="checkbox"/> Yes        | <input type="checkbox"/> No            |   |
| 14. Fully Manual Doors?             | <input type="checkbox"/> Yes                   | <input checked="" type="checkbox"/> No |   |
| 15. Cont. D.C.B. to Close Doors?    | <input type="checkbox"/> Yes                   | <input checked="" type="checkbox"/> No |   |
| 16. Cont. D.C.B. for Fire Phase 1?  | <input type="checkbox"/> Yes                   | <input checked="" type="checkbox"/> No | <input type="checkbox"/> N/A if no Fire Service   |
| 17. Moment. D.O.B. Door Opening?    | <input checked="" type="checkbox"/> No         | <input type="checkbox"/> Front         | <input type="checkbox"/> Rear <input type="checkbox"/> Both <input type="checkbox"/> Hall <input type="checkbox"/> Car <input type="checkbox"/> All |
| 18. Doors to Open if Parked?        | <input checked="" type="checkbox"/> None       | <input type="checkbox"/> Front         | <input type="checkbox"/> Rear <input type="checkbox"/> Both   |
| 19. Doors to Open on Main Fire?     | <input checked="" type="checkbox"/> N/A        | <input type="checkbox"/> Front         | <input type="checkbox"/> Rear <input type="checkbox"/> Both   |
| 20. Doors to Open on Alt. Fire?     | <input checked="" type="checkbox"/> N/A        | <input type="checkbox"/> Front         | <input type="checkbox"/> Rear <input type="checkbox"/> Both   |
| 21. Leave Doors Open on CTL?        | <input type="checkbox"/> Yes                   | <input type="checkbox"/> No            | <input checked="" type="checkbox"/> N/A if no CTL or CTF input  |
| 22. Limited Door Re-Open Option?    | <input type="checkbox"/> Yes                   | <input checked="" type="checkbox"/> No |   |
| 23. Reduce HCT with Photo Eye?      | <input type="checkbox"/> Yes                   | <input checked="" type="checkbox"/> No |   |
| 24. Leave Doors Open on EPI?        | <input type="checkbox"/> Yes                   | <input type="checkbox"/> No            | <input checked="" type="checkbox"/> N/A if no Emergency Power   |
| 25. Doors to Open if No Demand?     | <input checked="" type="checkbox"/> None       | <input type="checkbox"/> Front         | <input type="checkbox"/> Rear <input type="checkbox"/> Both   |
| 26. Const Press. Op. Bypass PHE?    | <input checked="" type="checkbox"/> Yes        | <input type="checkbox"/> No            |   |
| 27. Door Type is:                   | <input checked="" type="checkbox"/> Horizontal | <input type="checkbox"/> Vertical      |   |

**Timers**

- |                                |                 |         |  |
|--------------------------------|-----------------|---------|--|
| 1. Short Door Timer            | <u>1</u>        | Seconds |  |
| 2. Car Call Door Timer         | <u>2</u>        | Seconds |  |
| 3. Hall Call Door Timer        | <u>4</u>        | Seconds |  |
| 4. Lobby Call Door Timer       | <u>6</u>        | Seconds |  |
| 5. Nudging Timer               | <u>40</u>       | Seconds | <input type="checkbox"/> N/A                                   |
| 6. Time Out of Service Timer   | <u>40</u>       | Seconds |  |
| 7. Motor Limit Timer           | <u>3.0</u>      | Minutes |  |
| 8. Valve Limit Timer           | <u>2.5</u>      | Minutes |  |
| 9. Door Hold Input Timer       | <u>0</u>        | Seconds |  |
| 10. Parking Delay Timer        | <u>        </u> | Minutes | <input checked="" type="checkbox"/> N/A if no Parking Floor    |
| 11. Fan/Light Output Timer     | <u>1</u>        | Minutes |  |
| 12. Hospital Emergency Timer   | <u>        </u> | Minutes | <input checked="" type="checkbox"/> N/A if no Hospital Service |
| 13. Door Open Protection Timer | <u>8</u>        | Seconds |  |
| 14. CTL Door Cycle Timer       | <u>        </u> | Seconds | <input checked="" type="checkbox"/> N/A if no CTL input        |

**Gongs and Lanterns**

1. Mounted in Hall or Car?       Hall       Car       N/A if Car and Hall Gongs
2. Double Strike on Down?       Yes       No
3. PFG Enable Button?       Yes       No
4. Egress Floor Arrival Gong?       No      \_\_\_\_\_ Main Egress Floor

**Spare Inputs**

1. FRON	12.	23.
2. FRBYP	13.	24.
3. FCOFF	14.	25.
4. FCHLD	15.	26.
5. FCCC	16.	27.
6. DCL	17.	28.
7. TEST	18.	29.
8. FRMR	19.	30.
9. FRHTW	20.	31.
10.	21.	32.
11.	22.	33.

**Spare Outputs**

1. FWL	12.	23.
2.	13.	24.
3.	14.	25.
4.	15.	26.
5.	16.	27.
6.	17.	28.
7.	18.	29.
8.	19.	30.
9.	20.	31.
10.	21.	32.
11.	22.	

**Extra Features**

1. PI Output Type       1 Wire per Floor       Binary Coded PIS
2. Floor Encoding Inputs?       Yes       No
3. Encode All Floors?       Yes       No       N/A if no Floor Encoding
4. Emergency Power Operation?       No      \_\_\_\_\_ Emergency Power Return Floor
5. Light Load Weighing?       N/A      \_\_\_\_\_ Light Load Car Limit
6. Photo Eye Anti-Nuisance?       No      \_\_\_\_\_ Consec. Stops without PHE Limit

**Extra Features**

7. Peripheral Device?	<input type="checkbox"/> Yes	<input checked="" type="checkbox"/> No	If yes, PA ver# _____	EMI? <input type="checkbox"/> Yes <input type="checkbox"/> No
PA COM 1 Media:	<input checked="" type="checkbox"/> N/A	<input type="checkbox"/> None	<input type="checkbox"/> Serial Cable	<input type="checkbox"/> Line Driver <input type="checkbox"/> Modem
PA COM 1 Device	<input checked="" type="checkbox"/> N/A	<input type="checkbox"/> Personal Computer	<input type="checkbox"/> CMS / MSD	<input type="checkbox"/> Graphic Display
		<input type="checkbox"/> CRT - No Keyboard	Color CRT?	<input type="checkbox"/> Yes <input type="checkbox"/> No
		<input type="checkbox"/> CRT w/ Keyboard	Color CRT?	<input type="checkbox"/> Yes <input type="checkbox"/> No
PA COM 2 Media:	<input checked="" type="checkbox"/> N/A	<input type="checkbox"/> None	<input type="checkbox"/> Serial Cable	<input type="checkbox"/> Line Driver <input type="checkbox"/> Modem
PA COM 2 Device	<input checked="" type="checkbox"/> N/A	<input type="checkbox"/> Personal Computer	<input type="checkbox"/> CMS / MSD	<input type="checkbox"/> Graphic Display
		<input type="checkbox"/> CRT - No Keyboard	Color CRT	<input type="checkbox"/> Yes <input type="checkbox"/> No
		<input type="checkbox"/> CRT w/ Keyboard	Color CRT	<input type="checkbox"/> Yes <input type="checkbox"/> No
PA COM 3 Media:	<input checked="" type="checkbox"/> N/A	<input type="checkbox"/> None	<input type="checkbox"/> Serial Cable	<input type="checkbox"/> Line Driver <input type="checkbox"/> Modem
PA COM 3 Device	<input checked="" type="checkbox"/> N/A	<input type="checkbox"/> Personal Computer	<input type="checkbox"/> CMS / MSD	<input type="checkbox"/> Graphic Display
		<input type="checkbox"/> CRT - No Keyboard	Color CRT	<input type="checkbox"/> Yes <input type="checkbox"/> No
		<input type="checkbox"/> CRT w/ Keyboard	Color CRT	<input type="checkbox"/> Yes <input type="checkbox"/> No
PA COM 4 Media:	<input checked="" type="checkbox"/> N/A	<input type="checkbox"/> None	<input type="checkbox"/> Serial Cable	<input type="checkbox"/> Line Driver <input type="checkbox"/> Modem
PA COM 4 Device	<input checked="" type="checkbox"/> N/A	<input type="checkbox"/> Personal Computer	<input type="checkbox"/> CMS / MSD	<input type="checkbox"/> Graphic Display
		<input type="checkbox"/> CRT - No Keyboard	Color CRT	<input type="checkbox"/> Yes <input type="checkbox"/> No
		<input type="checkbox"/> CRT w/ Keyboard	Color CRT	<input type="checkbox"/> Yes <input type="checkbox"/> No
8. Automatic Floor Stop Option?	<input checked="" type="checkbox"/> No	_____ Floor		
9. Car Call Cancel with Direction Reversal?	<input type="checkbox"/> Yes	<input checked="" type="checkbox"/> No		
10. Cancel Car Calls behind Car?	<input type="checkbox"/> Yes	<input checked="" type="checkbox"/> No		
11. CE Electronics Interface?	<input type="checkbox"/> Yes	<input checked="" type="checkbox"/> No		
12. Massachusetts EMS Service?	<input checked="" type="checkbox"/> N/A	_____ EMS Service Floor		
13. Master Software Key?	<input type="checkbox"/> Activated	<input checked="" type="checkbox"/> Deactivated	<input type="checkbox"/> Enabled	
14. PI Turned off if No Demand?	<input type="checkbox"/> Yes	<input checked="" type="checkbox"/> No		
15. Hospital Emergency Oper. (This Car)?	<input type="checkbox"/> Yes	<input checked="" type="checkbox"/> No		
16. Hospital Calls Front Floor (This car)?	<input type="checkbox"/> 1 <input type="checkbox"/> 2 <input type="checkbox"/> 3 <input type="checkbox"/> 4 <input type="checkbox"/> 5 <input type="checkbox"/> 6 <input type="checkbox"/> 7 <input type="checkbox"/> 8 <input type="checkbox"/> 9 <input type="checkbox"/> 10 <input type="checkbox"/> 11 <input type="checkbox"/> 12 <input type="checkbox"/> 13 <input type="checkbox"/> 14 <input type="checkbox"/> 15 <input type="checkbox"/> 16 <input type="checkbox"/> 17 <input type="checkbox"/> 18 <input type="checkbox"/> 19 <input type="checkbox"/> 20 <input type="checkbox"/> 21 <input type="checkbox"/> 22 <input type="checkbox"/> 23 <input type="checkbox"/> 24 <input type="checkbox"/> 25 <input type="checkbox"/> 26 <input type="checkbox"/> 27 <input type="checkbox"/> 28 <input type="checkbox"/> 29 <input type="checkbox"/> 30 <input type="checkbox"/> 31 <input type="checkbox"/> 32			
Hospital Calls Rear Floor (This car)?	<input type="checkbox"/> 1 <input type="checkbox"/> 2 <input type="checkbox"/> 3 <input type="checkbox"/> 4 <input type="checkbox"/> 5 <input type="checkbox"/> 6 <input type="checkbox"/> 7 <input type="checkbox"/> 8 <input type="checkbox"/> 9 <input type="checkbox"/> 10 <input type="checkbox"/> 11 <input type="checkbox"/> 12 <input type="checkbox"/> 13 <input type="checkbox"/> 14 <input type="checkbox"/> 15 <input type="checkbox"/> 16 <input type="checkbox"/> 17 <input type="checkbox"/> 18 <input type="checkbox"/> 19 <input type="checkbox"/> 20 <input type="checkbox"/> 21 <input type="checkbox"/> 22 <input type="checkbox"/> 23 <input type="checkbox"/> 24 <input type="checkbox"/> 25 <input type="checkbox"/> 26 <input type="checkbox"/> 27 <input type="checkbox"/> 28 <input type="checkbox"/> 29 <input type="checkbox"/> 30 <input type="checkbox"/> 31 <input type="checkbox"/> 32			
17. Hospital Emergency Oper. (Other car)?	<input type="checkbox"/> Yes	<input type="checkbox"/> No	<input checked="" type="checkbox"/> N/A if Simplex	
18. Other Car Hospital Calls Front Floor?	<input type="checkbox"/> 1 <input type="checkbox"/> 2 <input type="checkbox"/> 3 <input type="checkbox"/> 4 <input type="checkbox"/> 5 <input type="checkbox"/> 6 <input type="checkbox"/> 7 <input type="checkbox"/> 8 <input type="checkbox"/> 9 <input type="checkbox"/> 10 <input type="checkbox"/> 11 <input type="checkbox"/> 12 <input type="checkbox"/> 13 <input type="checkbox"/> 14 <input type="checkbox"/> 15 <input type="checkbox"/> 16 <input type="checkbox"/> 17 <input type="checkbox"/> 18 <input type="checkbox"/> 19 <input type="checkbox"/> 20 <input type="checkbox"/> 21 <input type="checkbox"/> 22 <input type="checkbox"/> 23 <input type="checkbox"/> 24 <input type="checkbox"/> 25 <input type="checkbox"/> 26 <input type="checkbox"/> 27 <input type="checkbox"/> 28 <input type="checkbox"/> 29 <input type="checkbox"/> 30 <input type="checkbox"/> 31 <input type="checkbox"/> 32			
Other Car Hospital Calls Rear Floor?	<input type="checkbox"/> 1 <input type="checkbox"/> 2 <input type="checkbox"/> 3 <input type="checkbox"/> 4 <input type="checkbox"/> 5 <input type="checkbox"/> 6 <input type="checkbox"/> 7 <input type="checkbox"/> 8 <input type="checkbox"/> 9 <input type="checkbox"/> 10 <input type="checkbox"/> 11 <input type="checkbox"/> 12 <input type="checkbox"/> 13 <input type="checkbox"/> 14 <input type="checkbox"/> 15 <input type="checkbox"/> 16 <input type="checkbox"/> 17 <input type="checkbox"/> 18 <input type="checkbox"/> 19 <input type="checkbox"/> 20 <input type="checkbox"/> 21 <input type="checkbox"/> 22 <input type="checkbox"/> 23 <input type="checkbox"/> 24 <input type="checkbox"/> 25 <input type="checkbox"/> 26 <input type="checkbox"/> 27 <input type="checkbox"/> 28 <input type="checkbox"/> 29 <input type="checkbox"/> 30 <input type="checkbox"/> 31 <input type="checkbox"/> 32			
19. Fire Bypasses Hospital?	<input type="checkbox"/> Yes	<input type="checkbox"/> No	<input checked="" type="checkbox"/> N/A if no Hospital Service	
20. High Speed Delay after Run?	<input type="checkbox"/> Yes	<input checked="" type="checkbox"/> No		
21. Sabbath Operation?	<input type="checkbox"/> Yes	<input checked="" type="checkbox"/> No		
22. Sabbath Up Calls Front Floor?	<input type="checkbox"/> 1 <input type="checkbox"/> 2 <input type="checkbox"/> 3 <input type="checkbox"/> 4 <input type="checkbox"/> 5 <input type="checkbox"/> 6 <input type="checkbox"/> 7 <input type="checkbox"/> 8 <input type="checkbox"/> 9 <input type="checkbox"/> 10 <input type="checkbox"/> 11 <input type="checkbox"/> 12 <input type="checkbox"/> 13 <input type="checkbox"/> 14 <input type="checkbox"/> 15 <input type="checkbox"/> 16 <input type="checkbox"/> 17 <input type="checkbox"/> 18 <input type="checkbox"/> 19 <input type="checkbox"/> 20 <input type="checkbox"/> 21 <input type="checkbox"/> 22 <input type="checkbox"/> 23 <input type="checkbox"/> 24 <input type="checkbox"/> 25 <input type="checkbox"/> 26 <input type="checkbox"/> 27 <input type="checkbox"/> 28 <input type="checkbox"/> 29 <input type="checkbox"/> 30 <input type="checkbox"/> 31 <input type="checkbox"/> 32			
Sabbath Up Calls Rear Floor?	<input type="checkbox"/> 1 <input type="checkbox"/> 2 <input type="checkbox"/> 3 <input type="checkbox"/> 4 <input type="checkbox"/> 5 <input type="checkbox"/> 6 <input type="checkbox"/> 7 <input type="checkbox"/> 8 <input type="checkbox"/> 9 <input type="checkbox"/> 10 <input type="checkbox"/> 11 <input type="checkbox"/> 12 <input type="checkbox"/> 13 <input type="checkbox"/> 14 <input type="checkbox"/> 15 <input type="checkbox"/> 16 <input type="checkbox"/> 17 <input type="checkbox"/> 18 <input type="checkbox"/> 19 <input type="checkbox"/> 20 <input type="checkbox"/> 21 <input type="checkbox"/> 22 <input type="checkbox"/> 23 <input type="checkbox"/> 24 <input type="checkbox"/> 25 <input type="checkbox"/> 26 <input type="checkbox"/> 27 <input type="checkbox"/> 28 <input type="checkbox"/> 29 <input type="checkbox"/> 30 <input type="checkbox"/> 31 <input type="checkbox"/> 32			

Extra Features

23. Sabbath Down Calls Front Floor? 1 2 3 4 5 6 7 8 9 10 11 12 13 14 15 16 17  
18 19 20 21 22 23 24 25 26 27 28 29 30 31 32
- Sabbath Down Calls Rear Floor? 1 2 3 4 5 6 7 8 9 10 11 12 13 14 15 16 17  
18 19 20 21 22 23 24 25 26 27 28 29 30 31 32
24. Levelling Sensors  Enabled  Disabled
25. KCE (Keyboard Controlled Elevator)  Enabled  Disabled  N/A if no Peripheral Board
26. Analog Load Weigher?  None  MCE  K-Tech
27. Independent Service Bypasses Security?  Yes  No  N/A if no Security
28. Attendant Service Bypasses Security?  Yes  No  N/A if no Security and Attendant Service
29. Car to Floor Return Floor: \_\_\_\_\_ Return Landing  N/A if no CTF Spare Input
30. Scrolling Speed:  Slow  Normal  Fast

---

# TABLE OF CONTENTS

---

IMPORTANT PRECAUTIONS AND NOTES .....	ix
---------------------------------------	----

---

## SECTION 1 PRODUCT DESCRIPTION

1.0	General Information .....	1-1
1.1	Car Controller Physical Description .....	1-2
1.2	Car Controller Functional Description .....	1-7
1.2.1	Car Operation Control (COC) .....	1-7
1.2.2	Car Communication Control (CCC) .....	1-9
1.2.3	Programming and Diagnostics Tools .....	1-9
1.2.4	Duplexing .....	1-9
1.3	Landing System Control Box .....	1-9

---

## SECTION 2 INSTALLATION

2.0	General Information .....	2-1
2.0.1	Site Selection .....	2-1
2.0.2	Environmental Considerations .....	2-1
2.0.3	Recommended Tools and Test Equipment .....	2-2
2.0.4	The Wiring Prints .....	2-2
2.1	Controller Installation .....	2-3
2.1.1	Controller Wiring Guidelines .....	2-3
2.2	General Wiring Guidelines .....	2-4
2.2.1	Ground Wiring .....	2-4
2.2.2	Main AC Power .....	2-5
2.2.3	Pump Motor Wiring .....	2-5
2.2.4	Phase Monitor Installation (SLA Series Phase Monitors) .....	2-5
2.3	Hoistway Control Equipment Installation .....	2-7
2.3.1	Installing the Landing System .....	2-7
2.3.2	Installing the Hoistway Limit Switches .....	2-7
2.3.3	Installing the Landing System Control Box (LS-QUTE) .....	2-7
2.3.4	Installing the Magnetic Strips on the Steel Tape .....	2-8
2.3.5	Door Operator Diode Installation (If Used) .....	2-8



---

## SECTION 3 START-UP SEQUENCE

3.0	General Information .....	3-1
3.1	Ground Check .....	3-1
3.2	Before Applying Power .....	3-1
3.3	Applying Power .....	3-2
3.3.1	Initial Adjustments and Power Phasing .....	3-2
3.3.2	Moving the Elevator on Inspection .....	3-3
3.3.3	Preparing the Car to Run on Automatic Operation .....	3-3
3.4	Preparation for Final Adjustment .....	3-4

---

## SECTION 4 FINAL ADJUSTMENT

4.0	General Information .....	4-1
4.1	Running on Automatic Operation .....	4-1
4.1.1	Diagnostic Messages and Input/output Signals .....	4-1
4.1.2	A Few Words about Absolute Floor Encoding .....	4-2
4.1.3	Registering Car Calls .....	4-3
4.1.4	Test Mode Operation .....	4-3
4.1.5	Switching to Automatic Operation .....	4-4
4.2	Final Adjustments .....	4-4
4.2.1	Door Operator Adjustments .....	4-4
4.2.2	Hydraulic Valves .....	4-4
4.2.3	Slowdown and Limit Switches .....	4-5
4.2.4	Hall Calls .....	4-5
4.2.5	Options .....	4-5
4.2.6	Door Open/close Protection .....	4-5
4.2.7	Motor Limit Timer .....	4-5
4.2.8	Valve Limit Timer .....	4-5
4.2.9	Stuck Button Protection .....	4-5
4.2.10	Relevel Operation .....	4-5

## SECTION 5 THE COMPUTER

5.0	About the PHC Series .....	5-1
5.1	The MC-PCA Computer Panel - Your Tool for Programming, Diagnostics and Data Communication .....	5-1
5.1.1	Indicators .....	5-1
5.1.1.1	Computer on Light .....	5-1
5.1.1.2	Vertical Status Indicator Lights .....	5-1
5.1.1.3	Diagnostics LCD Display .....	5-2
5.1.2	Switches, Buttons & Adjustments .....	5-2
5.1.2.1	Computer Reset Pushbutton .....	5-2
5.1.2.2	N, S, +, & - Pushbuttons .....	5-2
5.1.2.3	Mode Selection F1-F8 Function Switches .....	5-3
5.1.2.4	Lcd Contrast Adjustment Trimpot .....	5-3
5.1.3	Terminals .....	5-3
5.1.3.1	Power Supply Terminal .....	5-3
5.1.3.2	Communication Port for Duplexing .....	5-3
5.1.3.3	Com Port 1 and 2 .....	5-3
5.1.4	Status Displays .....	5-3
5.2	Computer Security .....	5-3
5.2.1	Password .....	5-4
5.3	Diagnostic Mode .....	5-4
5.3.1	Getting into Diagnostic Mode .....	5-4
5.3.2	Function of N Pushbutton .....	5-4
5.3.3	Function of S Pushbutton .....	5-5
5.3.4	Function of + Pushbutton .....	5-5
5.3.5	Function of - Pushbutton .....	5-5
5.3.6	Format of LCD Display .....	5-5
5.3.6.2	Status Message .....	5-6
5.3.6.3	Elevator Position .....	5-9
5.3.6.4	Computer Internal Memory .....	5-9
5.3.7	Troubleshooting Using the Computer's Internal Memory .....	5-11
5.3.8	Troubleshooting Specific Problems .....	5-13
5.3.8.1	Problem: the BFD/TFD Error Message Is Flashing on the Display .....	5-13
5.3.8.2	Problems with Calls .....	5-15
5.3.8.3	Problems with Doors .....	5-15

5.4	Program Mode .....	5-15
5.4.1	General Description of Program Mode .....	5-15
5.4.1.1	Viewing Menus on the LCD Display .....	5-15
5.4.1.2	Viewing Options Within a Menu .....	5-16
5.4.1.3	Changing a Value .....	5-16
5.4.1.4	Saving the New Values .....	5-16
5.4.1.5	Restoring Original Values .....	5-17
5.4.1.6	Step-by-step Example .....	5-17
5.4.2	Basic Feature Menu Options .....	5-18
5.4.2.1	Simplex or Duplex? .....	5-18
5.4.2.2	Operation (Dispatching Operation) .....	5-18
5.4.2.3	Top Landing Served? .....	5-18
5.4.2.4	Car Doors Are Walk-thru? .....	5-18
5.4.2.5	Car Serves FRNT/FLR 1? .....	5-18
5.4.2.6	Car Serves REAR/FLR 1? .....	5-18
5.4.2.7	Parking Floor .....	5-19
5.4.2.8	Secondary Parking Floor .....	5-19
5.4.2.9	Lobby Floor .....	5-19
5.4.2.10	Car Identifier .....	5-19
5.4.2.11	Number of IOX Boards? .....	5-19
5.4.2.12	Number of I4O Boards? .....	5-19
5.4.2.13	Number of AIOX Boards? .....	5-19
5.4.3	Fire Service Menu Options .....	5-19
5.4.3.1	Fire Service Operation? .....	5-19
5.4.3.2	Fire Phase 1 Main Floor .....	5-19
5.4.3.3	Fire Phase 1 Alt. Floor .....	5-19
5.4.3.4	Fire Svce. Code .....	5-20
5.4.3.5	Bypass Stop Sw. On Phase 1? .....	5-20
5.4.3.6	Honeywell Fire Operation? .....	5-20
5.4.3.7	New York City Fire Phase 2 and ANSI 89? .....	5-20
5.4.3.8	White Plains, NY Fire Code? .....	5-20
5.4.4	Door Operation Menu Options .....	5-20
5.4.4.1	Nudging? .....	5-20
5.4.4.2	Stuck Photo Eye Protection? .....	5-20
5.4.4.3	Sequential Door Oper. (F/r)? .....	5-21
5.4.4.4	Car Call Cancels Door Time? .....	5-21
5.4.4.5	Nudging During Fire Ph. 1? .....	5-21
5.4.4.6	Retiring Cam Option? .....	5-21
5.4.4.7	Pre-opening? .....	5-21
5.4.4.8	Mechanical Safety Edge? .....	5-21
5.4.4.9	Nudging Output/buzzer Only? .....	5-21
5.4.4.10	D.C.B. Cancels Door Time? .....	5-21
5.4.4.11	Leave Doors Open on PTI/ESS? .....	5-22
5.4.4.12	Nudging During Fire Phase 2? .....	5-22
5.4.4.13	Dir. Preference until DLK? .....	5-22
5.4.4.14	Fully Manual Doors? .....	5-22

5.4.4.15	Cont. D.C.B. to Close Doors?	5-22
5.4.4.16	Cont. D.C.B. for Fire Ph 1?	5-22
5.4.4.17	Moment. D.O.B. Door Opening ?	5-22
5.4.4.18	Doors to Open If Parked:	5-22
5.4.4.19	Doors to Open on Main Fire?	5-23
5.4.4.20	Doors to Open on Alt Fire?	5-23
5.4.4.21	Leave Doors Open on CTL?	5-23
5.4.4.22	Limited Door Re-open Option	5-23
5.4.4.23	Reduce HCT with Photo Eye	5-23
5.4.4.24	Leave Doors Open on EPI	5-23
5.4.4.25	Doors to Open If No Demand:	5-23
5.4.4.26	Const. Press Op. Bypass PHE?	5-23
5.4.4.27	Door Type Is	5-23
5.4.5	Timer Menu Options	5-23
5.4.5.1	Short Door Timer	5-23
5.4.5.2	Car Call Door Timer	5-24
5.4.5.3	Hall Call Door Timer	5-24
5.4.5.4	Lobby Door Timer	5-24
5.4.5.5	Nudging Timer	5-24
5.4.5.6	Time out of SVCE. Timer	5-24
5.4.5.7	Motor Limit Timer	5-24
5.4.5.8	Valve Limit Timer	5-24
5.4.5.9	Door Hold Input Timer	5-24
5.4.5.10	Parking Delay Timer	5-24
5.4.5.11	Fan/light Output Timer	5-24
5.4.5.12	Hospital Emerg. Timer	5-25
5.4.5.13	Door Open Protection Timer	5-25
5.4.5.14	CTL Door Open Timer	5-25
5.4.6	Gongs/lanterns Menu Options	5-25
5.4.6.1	Mounted in Hall or Car?	5-25
5.4.6.2	Double Strike on Down?	5-25
5.4.6.3	PFG Enable Button? (Passing Floor Gong Enable Button)	5-25
5.4.6.4	Egress Floor Arrival Gong? / Main Egress Floor #	5-25
5.4.7	Spare Inputs Menu Options	5-25
5.4.8	Spare Outputs Menu Options	5-29
5.4.9	Extra Features Menu Options	5-32
5.4.9.1	Pi Output Type	5-32
5.4.9.2	Floor Encoding Inputs?	5-32
5.4.9.3	Encode All Floors?	5-32
5.4.9.4	Emergency Power Operation? / Emergency Power Return Floor	5-32
5.4.9.5	Light Load Weighing? / Light Load Car Call Limit	5-32
5.4.9.6	Photo Eye Anti-nuisance? / Consec Stops W/o PHE Limit	5-32
5.4.9.7	Peripheral Device?	5-32
5.4.9.8	Automatic Floor Stop Option? / Automatic Stop Floor #?	5-33
5.4.9.9	CC Cancel W/dir Reversal?	5-33
5.4.9.10	Cancel Car Calls Behind Car?	5-33
5.4.9.11	CE Electronics Interface?	5-33

5.4.9.12	Massachusetts Ems Service? / Ems Service Floor #	5-33
5.4.9.13	Master Software Key	5-33
5.4.9.14	Pi Turned off If No Demand?	5-33
5.4.9.15	Hospital Emerg. Operation?	5-34
5.4.9.16	Fire Bypasses Hospital?	5-35
5.4.9.17	High Speed Delay after Run?	5-35
5.4.9.18	Sabbath Operation	5-35
5.4.9.19	Leveling Sensor Enabled/disabled	5-35
5.4.9.20	KCE Enable / Disable	5-35
5.4.9.21	Analog Load Weigher?	5-35
5.4.9.22	Ind. Bypass Security?	5-35
5.4.9.23	ATS. Bypass Security?	5-36
5.4.9.24	Car to Floor Return Floor	5-36
5.4.9.25	Scrolling Speed	5-36
5.5	External Memory Mode	5-36
5.5.1	Getting into External Memory Mode	5-36
5.5.2	Function of N Pushbutton	5-36
5.5.3	Function of S Pushbutton	5-36
5.5.4	Function of + Pushbutton	5-36
5.5.5	Function of – Pushbutton	5-37
5.5.6	Troubleshooting Using External Memory Mode	5-37
5.6	System Mode	5-40
5.6.1	Building Security Menu	5-40
5.6.2	Passcode Request Menu	5-42
5.6.3	Load Weigher Thresholds	5-43
5.6.4	Analog Load Weigher Learn Function	5-44
5.7	Duplexing	5-46
5.7.1	Dispatching Algorithm	5-46
5.7.2	Hardware Connections	5-46
5.7.3	Troubleshooting	5-46

---

## SECTION 6 TROUBLESHOOTING

6.0	General Information	6-1
6.1	Tracing Signals in the Controller	6-1
6.2	Door Logic	6-3
6.3	Call Logic	6-6
6.3.1	Normal Operation	6-6
6.3.2	Preparation for Troubleshooting Call Circuits	6-7
6.3.3	Troubleshooting the Call Circuits	6-7

6.4	Using the Optional CRT for Troubleshooting	6-14
6.4.1	Graphic Display of Elevator (F3) Screen	6-14
6.4.2	MCE Special Events Calendar Entries (F7 - 1) Screen	6-14
6.5	Using the MLT / VLT Data Trap	6-16

---

## APPENDIX

Appendix A	Original Programmed Values and the Record of Changes	A-1
Appendix B	Nomenclature Page	A-5
Appendix C	Elevator Security Information and Operation	A-7
Appendix D	Flex Talk Option	A-9
Appendix E	LS-QUTE Landing System Assembly Drawings	A-12

---

## INDEX

---

## FIGURES

Figure 1.1	Typical Physical Layout	1-2
Figure 1.2	HC-PCI/O Input Output Details	1-3
Figure 1.3	HC-CI/O-E Call Input/Output Board	1-3
Figure 1.4	HC-IOX Input/Output Expander Board	1-4
Figure 1.5	HC-I4O Input/Output Expander Board	1-4
Figure 1.6	MC-PCA Computer Board	1-5
Figure 1.7	MC-PA Peripherals Adapter Board (optional)	1-5
Figure 1.8	Main Relay Board (HC-RBH)	1-6
Figure 1.9	Car Controller Functional Layout	1-8
Figure 1.10	LS-STAN Car Top Control Box	1-10
Figure 1.11	LS-QUTE Car Top Control Box	1-10
Figure 2.1	Ground Wiring to Controller Cabinets	2-4
Figure 2.2	SLA Series Phase Monitor Wiring Diagrams	2-6
Figure 5.1	MC-PCA Computer Panel Board Layout	5-2
Figure 6.1	HC-PCI/O Power and Call Input/Output Board Quick Reference	6-2
Figure 6.2	HC-RBH Main Relay Board Detail	6-3
Figure 6.3	Door operation flowchart	6-5
Figure 6.4	HC-CI/O Call Input/Output Board Quick Reference	6-9
Figure 6.5	MC-PCA Quick Reference	6-12
Figure 6.6	MC-PA Quick Reference	6-13
Figure 6.7	Graphic Display of Elevator (F3) Screen (Color CRT)	6-14
Figure 6.8	Special Events Calendar - Display Special Event Entries (F7 - 1) Screen	6-15
Figure D.1	Flex-Talk Board	A-9
Figure D.2	Speaker Dimensions	A-11
Figure E.1	LS QUTE Enclosure Assembly	A-12
Figure E.2	LS QUTE Wiring Diagram	A-13

---

## TABLES

Table 5.1	Status Indicators .....	5-1
Table 5.2	Error Status Messages and Response Chart .....	5-6
Table 5.3	Computer Internal Memory Chart .....	5-10
Table 5.4	Alphabetized Flags/Variables and Their Locations .....	5-11
Table 5.5	Using the Program Mode .....	5-17
Table 5.6	Computer External Memory Chart .....	5-38
Table 5.7	Computer's Hospital Call and Eligibility Memory Chart .....	5-39
Table 6.1	Special Events Calendar Messages .....	6-15
Table 6.2	MLT / VLT Data Trap Memory Chart .....	6-17
Table D.1	Diagnostic Table .....	A-10

# IMPORTANT PRECAUTIONS & NOTES

We strongly recommend that you read this manual carefully before proceeding with installation. Throughout this manual you will see icons followed by a WARNING, CAUTION, or NOTE. These icons denote the following:



**WARNING:** Operating procedures and practices which, if not done correctly, may result in personal injury or substantial damage to equipment.



**CAUTION:** Operating procedures and practices which, if not observed, may result in some damage to equipment.



**NOTE:** Procedures, practices or information which are intended to be immediately helpful and informative.

The following general rules and safety precautions must be observed for safe and reliable operation of your system.



This controller may be shipped without the final running program. However you may install the unit, hook-up and run your elevator on Inspection operation. Call MCE about a week before you are ready to turn the elevator over to full automatic operation so the running program can be shipped to you.

If you need to change a program chip on a computer board make sure you read the instructions and know exactly how to install the new chip. Plugging these devices in backwards may damage your chip.



Elevator control products must be installed by experienced field personnel. This manual does not address code requirements. The field personnel must know all the rules and regulations pertaining to the safe installation and running of elevators.

This equipment is an O.E.M. product designed and built to comply with ASME A17.1, CAN/CSA-B44.1/ASME-A17.5 and National Electrical Code and must be installed by a qualified contractor. It is the responsibility of the contractor to make sure that the final installation complies with any local codes and is installed safely.

The 3-phase AC power supply to this equipment must come from a fused disconnect switch or circuit breaker that is sized in conformance with all applicable national, state and local electrical codes, in order to provide the necessary overload protection for the Drive Unit and motor. Incorrect motor branch circuit protection will void the warranty and may create a hazardous condition.





Proper grounding is vitally important to the safe and successful operation of your system. Bring your ground wire to the system subplate. You must choose the proper conductor size and minimize the resistance to ground by using shortest possible routing. See National Electrical Code Article 250-95, or the related local applicable code.



You must *not* connect the output triacs *directly* to a hot bus (2, 3 or 4 bus). This can damage the triacs. PIs, direction arrows and terminals 40 & 42 are examples of outputs that can be damaged this way. Note: miswiring terminal 39 into 40 can damage the fire warning indicator triac.



The HC-PCI/O and HC-CI/O-E boards are equipped with quick disconnect terminals. During the original installation, you may want to remove the terminal connector, hook up your field wires to it, test it for no shorts to ground (1 bus) and to terminals 2, 3 and 4 before plugging these terminals back into the PC boards.

#### ENVIRONMENTAL CONSIDERATIONS:

Keep the machine room clean. Controllers are generally in NEMA 1 enclosures. Do not install the controller in a dusty area. Do not install the controller in a carpeted area. Keep room temperature between 32°F and 104° F (0° to 40°C). Avoid condensation on the equipment. Do not install the controller in a hazardous location and where excessive amounts of vapors or chemical fumes may be present. Make sure that the power line fluctuations are within  $\pm 10\%$ .

The controller should be installed nearest to the hoist motor, such that length of the connecting wires should not exceed more than 100 feet. If wire from controller to hoist motor is more than 100 feet, contact MCE.

## LIMITED WARRANTY

Motion Control Engineering (manufacturer) warrants its products for a period of 15 months from the date of shipment from its factory to be free from defects in workmanship and materials. Any defect appearing more than 15 months from the date of shipment from the factory shall be deemed to be due to ordinary wear and tear. Manufacturer, however, assumes no risk or liability for results of the use of the products purchased from it, including, but without limiting the generality of the forgoing: (1) The use in combination with any electrical or electronic components, circuits, systems, assemblies or any other material or equipment (2) Unsuitability of this product for use in any circuit, assembly or environment. Purchasers' rights under this warranty shall consist solely of requiring the manufacturer to repair, or in manufacturer's sole discretion, replace free of charge, F.O.B. factory, any defective items received at said factory within the said 15 months and determined by manufacturer to be defective. The giving of or failure to give any advice or recommendation by manufacturer shall not constitute any warranty by or impose any liability upon the manufacturer. This warranty constitutes the sole and exclusive remedy of the purchaser and the exclusive liability of the manufacturer, AND IN LIEU OF ANY AND ALL OTHER WARRANTIES, EXPRESSED, IMPLIED, OR STATUTORY AS TO MERCHANTABILITY, FITNESS, FOR PURPOSE SOLD, DESCRIPTION, QUALITY PRODUCTIVENESS OR ANY OTHER MATTER. In no event will the manufacturer be liable for special or consequential damages or for delay in performance of this warranty.

Products that are not manufactured by MCE (such as drives, CRT's, modems, printers, etc.) are not covered under the above warranty terms. MCE, however, extends the same warranty terms that the original manufacturer of such equipment provide with their product (refer to the warranty terms for such products in their respective manual).

# SECTION 1

## PRODUCT DESCRIPTION

### 1.0 GENERAL INFORMATION

MCE's HMC-1000 Series PHC programmable elevator controller is designed to exhibit the characteristics listed below in a hydraulic elevator installation. The Series PHC controller was designed to save time during installation and troubleshooting, but it is still very important that the field personnel who work with this equipment familiarize themselves with this manual before attempting to install the equipment.

#### PRINCIPAL CHARACTERISTICS

Number of Stops	16	Environment:
Maximum Number of Cars	2	32° to 104° F (0° to 40° C) ambient
Field Programmable		12,000 ft altitude
		95% humidity

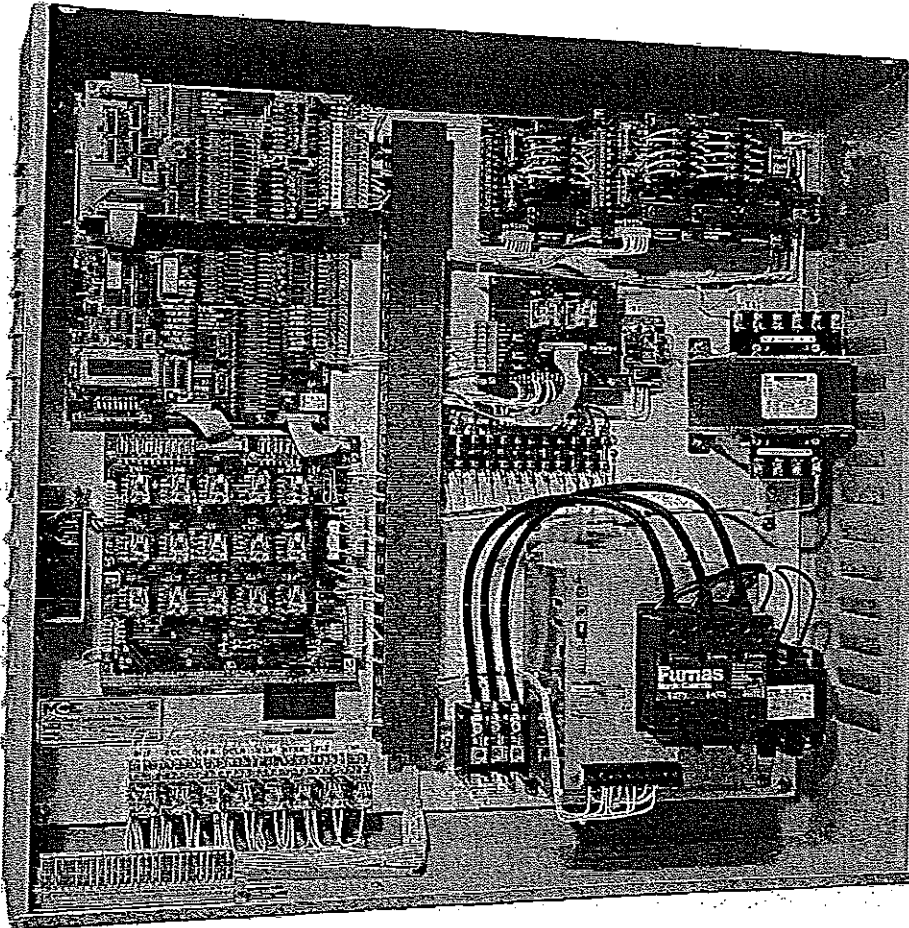

**EQUIPMENT CATEGORIES** - The HMC-1000 Series PHC hydraulic controller consists of three major pieces of equipment:

- Controller Unit
- Car Top Selector (Landing System)
- Peripherals

## 1.1 CAR CONTROLLER PHYSICAL DESCRIPTION

Figure 1.1 shows a typical layout of the Car Controller in a standard MCE cabinet. A brief description of each block follows:

**FIGURE 1.1 Typical Physical Layout**

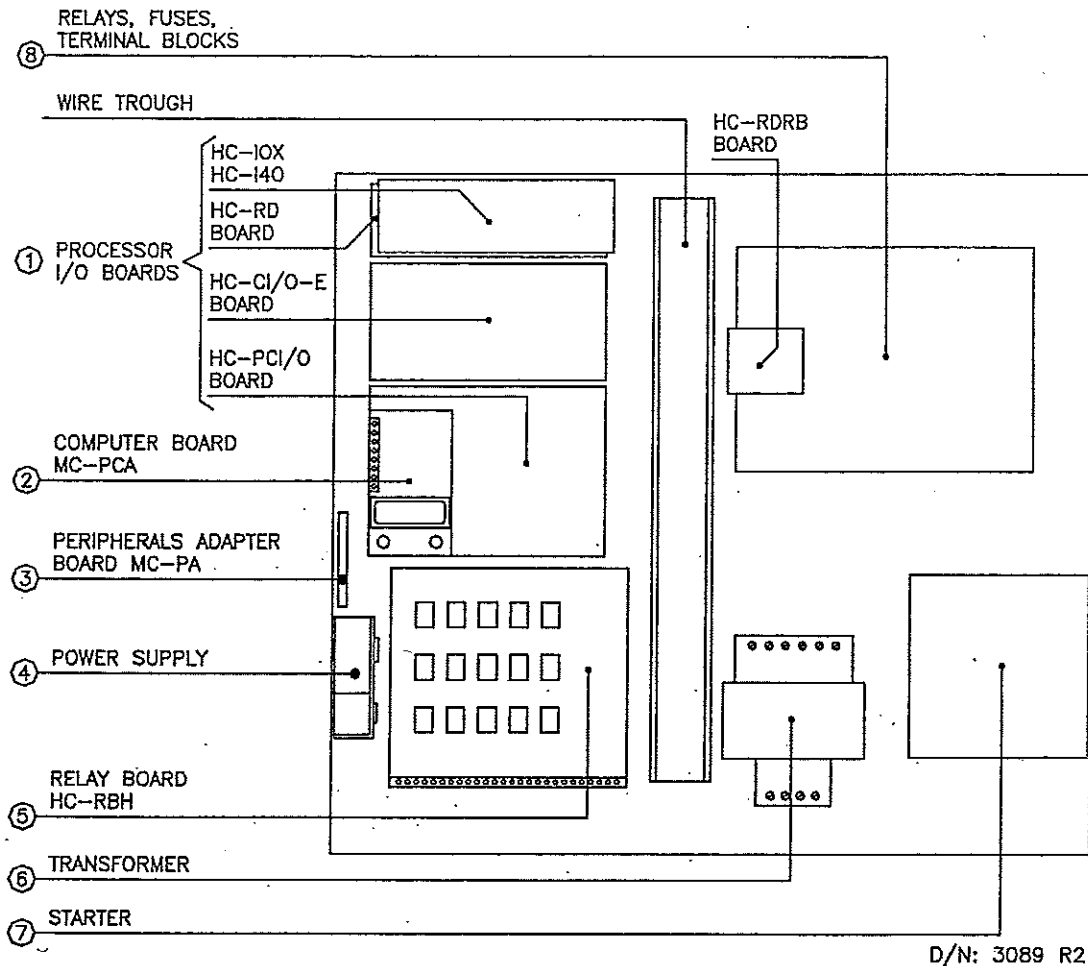

1. **INPUT/OUTPUT BOARDS** - This block consists of a number of different Input/Output boards. The following is a list of boards that could be used in this block:

- HC-PCI/O Power and Call Input/Output board
- HC-CI/O-E Call Input/Output board (optional)
- HC-RD Rear Door Logic board (optional)
- HC-IOX Input/Output Expander board (optional)
- HC-I4O Input/Output Expander board (optional)

Note that the HC-CI/O-E, HC-RD, HC-IOX and HC-I4O boards are optional and may be required depending on system requirements (i.e., number of landings served).

**HC-PCI/O Power and Call Input/Output board** - This board provides the following:

- 22 input signals
- 12 output signals
- PI output terminals
- 2 gong output terminals
- 10 call input and output terminals
- 2 direction arrow output terminals
- 1 passing floor gong output terminal

For details of each input and output signal and the associated terminals, see Figure 1.2.

FIGURE 1.2 HC-PCI/O Input Output Details

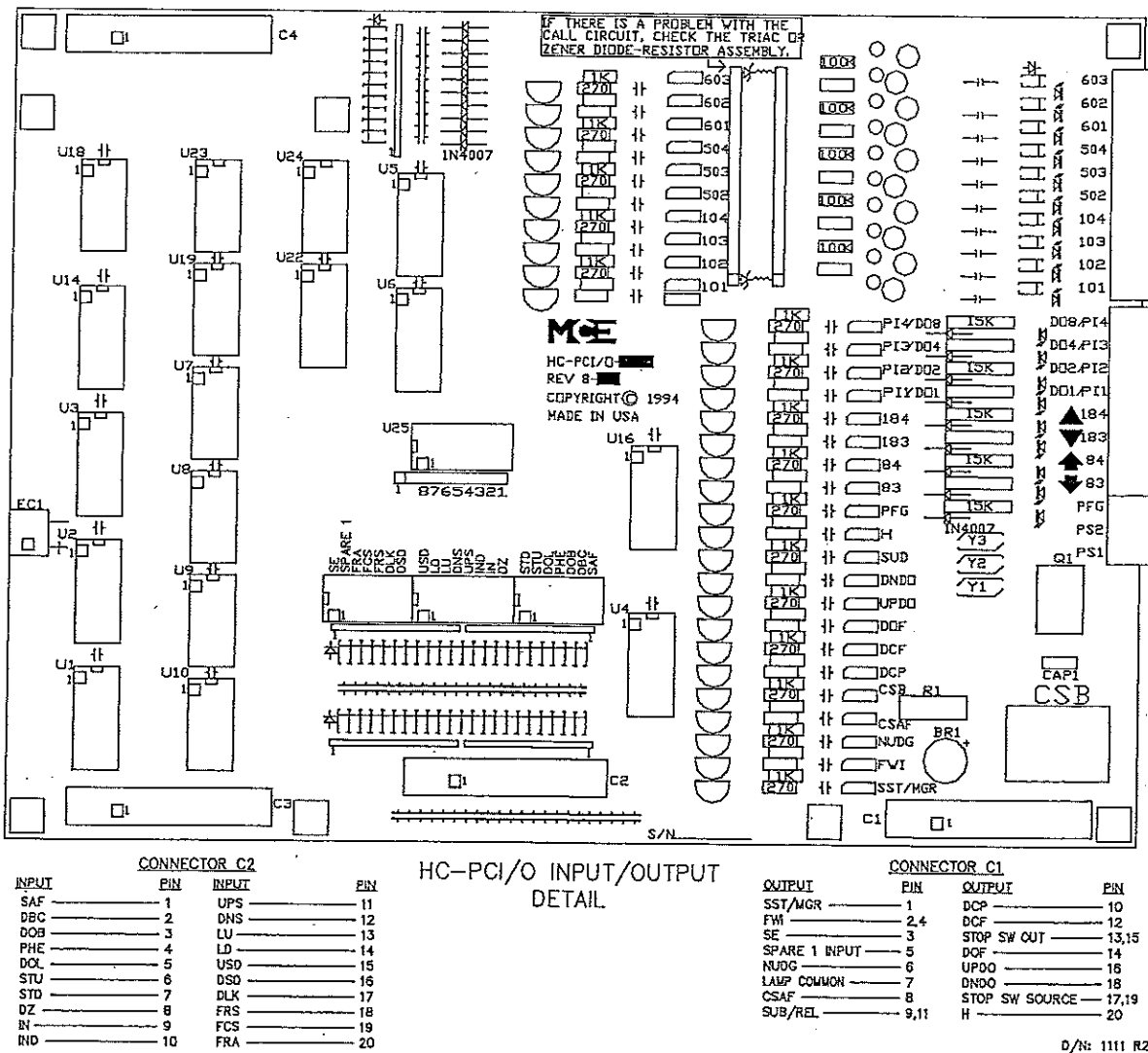
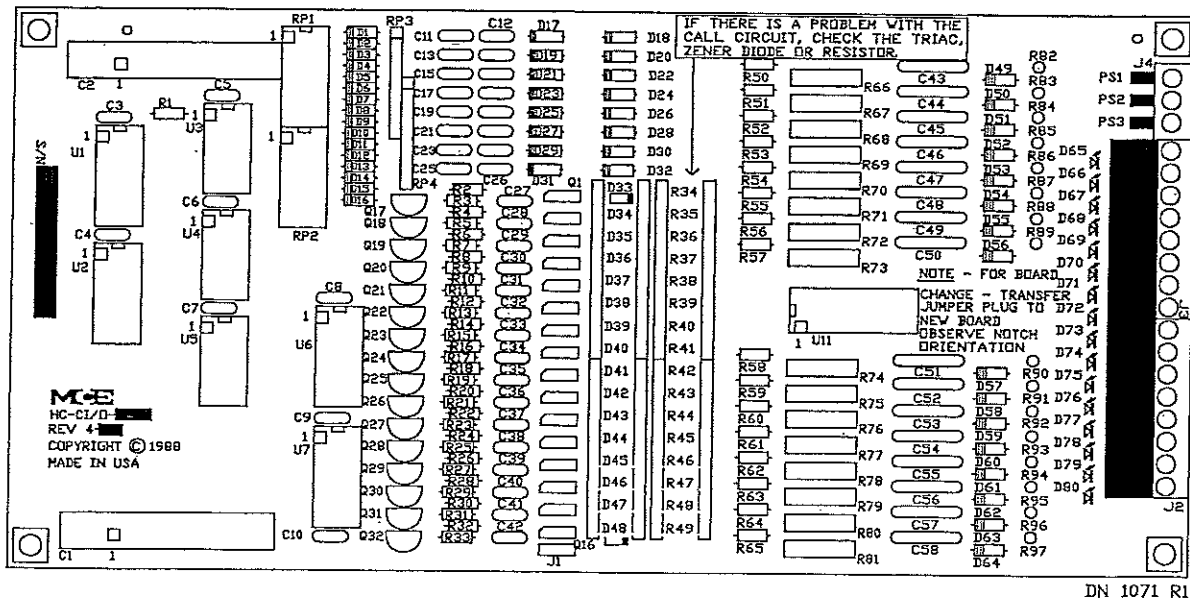

FIGURE 1.3 HC-CI/O-E Call Input/Output Board



HC-CI/O-E Call Input/Output Board - See Figure 1.3. This board provides the following:

- 4 PI output terminals
- 12 call input and output terminals

HC-RD Rear Door Logic Board - This board (not shown) provides the inputs and outputs required for independent rear doors.

FIGURE 1.4 HC-IOX Input/Output Expander Board

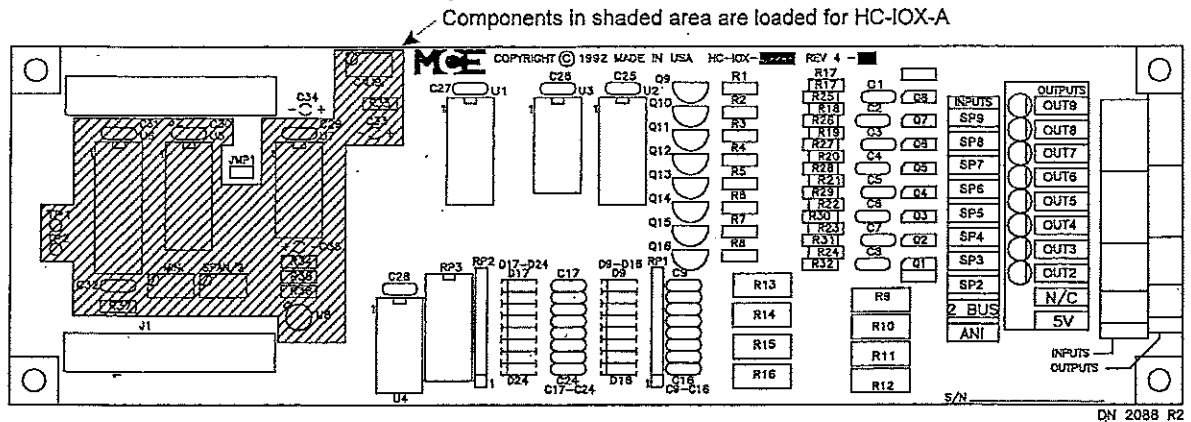

HC-IOX Input/Output Expander Board - This is a multi-purpose input/output board designed to accommodate additional inputs and outputs as required, such as floor encoding signals, etc.

FIGURE 1.5 HC-I4O Input/Output Expander Board

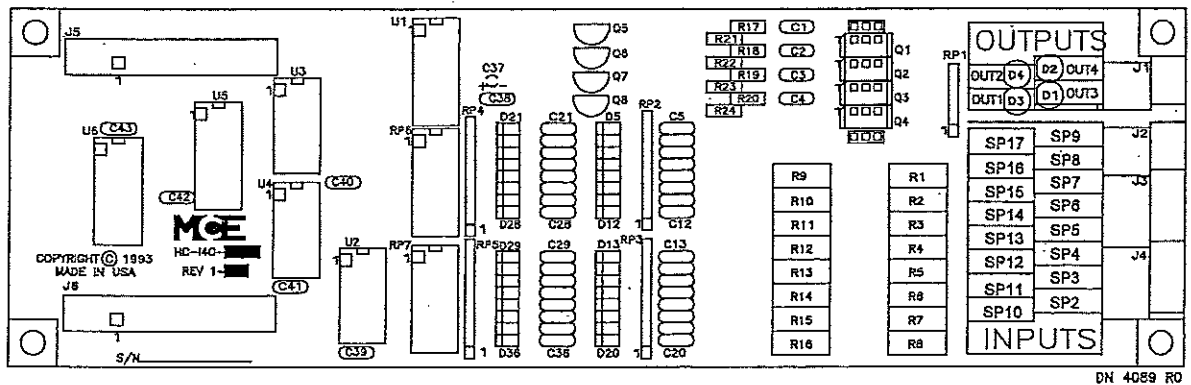

HC-I4O Input/Output Expander Board - This is a multi-purpose input/output board designed to accommodate additional inputs and outputs as required.

2. MC-PCA Main Computer Board - This board is mounted on the top of the HC-PCI/O board (see Figure 1.6). The main computer board is responsible for:

- Car Operation Control
- Car Communication Control
- Duplexing
- Programming and Diagnostic Tools



3. **MC-PA Peripherals Adapter Board** - The optional MC-PA board contains the COM ports used for serial communication with peripherals such as CRTs and PCs through direct connection or through line drivers or modems (see Figure 1.7). This board also stores the events displayed on the Special Events Calendar screen on a peripheral device.
4. **POWER SUPPLY** - The power supply is a single output linear power supply that provides +5 VDC power to the computer and its peripheral boards.

**FIGURE 1.8 Main Relay Board (HC-RBH)**

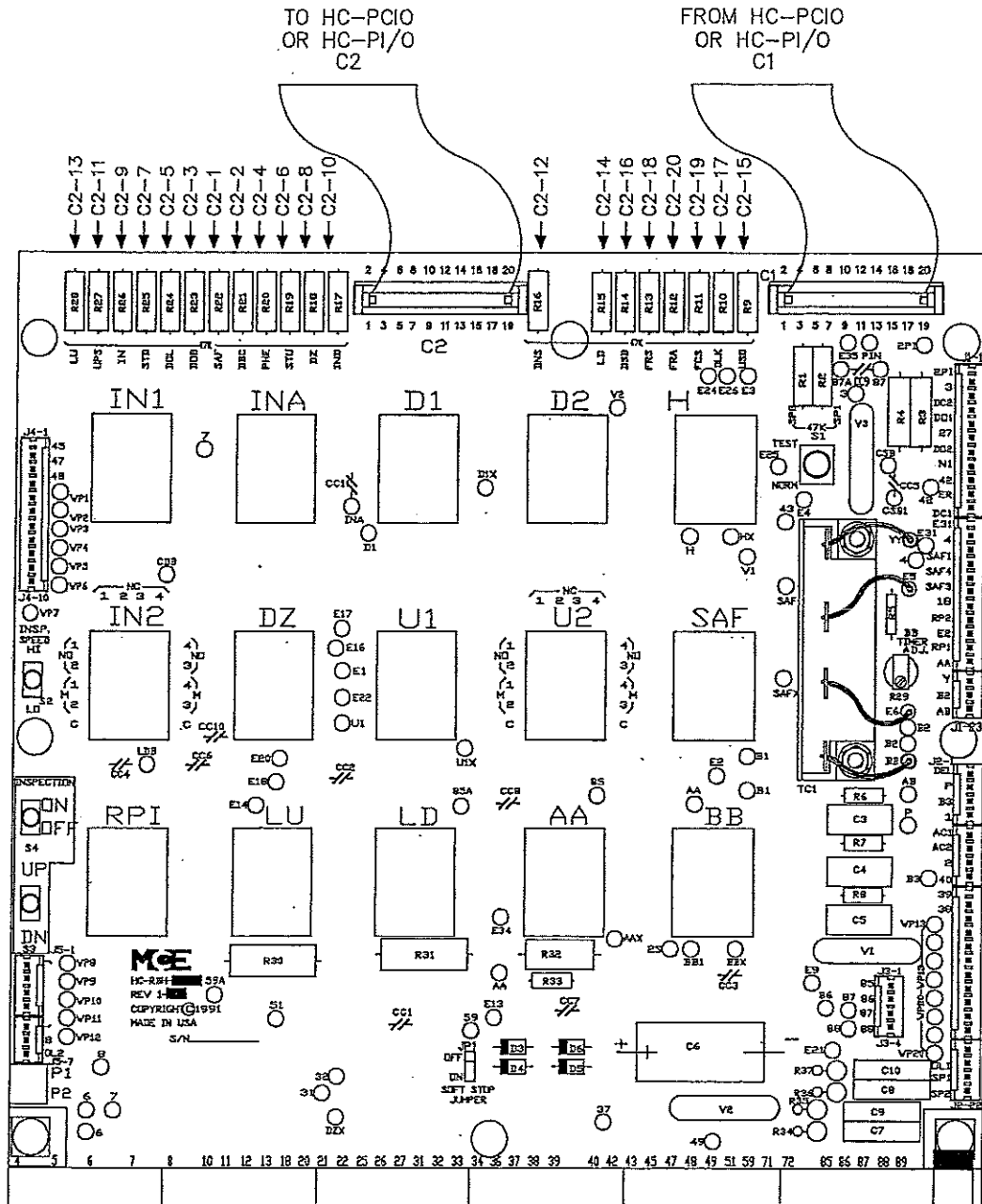

D/N: 1399 R2

5. **HC-RBH Main Relay Board** - This board satisfies many of the code requirements for relay contact redundancy and the requirements for normal terminal stopping devices. It also provides the necessary circuitry for running the car on Inspection or Access without the benefit of computers. This board, along with the HC-PCIO board, comprises the high voltage interface between the MC-PCA computer and the individual



car logic functions such as door operation, direction outputs, direction sensing, pump and valve control, main safety circuits, leveling circuitry, etc. This board typically contains 15 four-pole relays as well as some terminals for field wiring. Test pads surround each relay for ease of troubleshooting. A TEST/NORMAL switch, Inspection UP/DN switch and Relay Panel Inspection switch are provided on this board .

6. **Transformers** - Transformers are usually located in the lower part of the cabinet.
7. **Starter** - The starter is usually located in the lower right-hand corner of the controller cabinet along with the associated terminal blocks for motor connections.
8. **Relays, Fuses and Terminal Blocks** - This block contains door operator circuitry, terminal blocks (for customer wiring), fuse holders, fuses, and any other circuitry needed for a specific job.

---

## 1.2 CAR CONTROLLER FUNCTIONAL DESCRIPTION

Functionally, the Control Unit is divided into two primary sections. Each section consists of the following functional blocks, as shown in Figure 1.9:

### Computer Section

- Car Operation Control
- Car Communication Control
- Duplexing
- Programming and Diagnostics Tools

### Power Section

- Door Circuits
- Pump Motor Control

### 1.2.1 CAR OPERATION CONTROL (COC)

**Normal Operation** - Normal car operation consists of responding to hall and car call demands, and operating the doors, as required.

**Special Operations** - The following are special operations controlled by the COC:

- Inspection/Access
- Independent Service
- Fire Service
- Emergency Power

For details of each operation, see MCE Specifications for Elevator Products. The special features and options are discussed in Section 5 of this manual.

**Discussion of Car Operation Control (COC)** - The Car Operation Control (COC) performs the elevator logic operations for the individual car. These functions are performed by the following circuit boards:

- HC-RBH Main Relay board
- MC-PCA Main Processor board
- HC-PCI/O Power Input/Output board
- HC-CI/O-E Call Input/Output board (optional)
- HC-RD Rear Door board (optional)
- HC-IOX Input/Output Expander board (optional)
- HC-I4O Input/Output Expander board (optional)

FIGURE 1.9 Car Controller Functional Layout

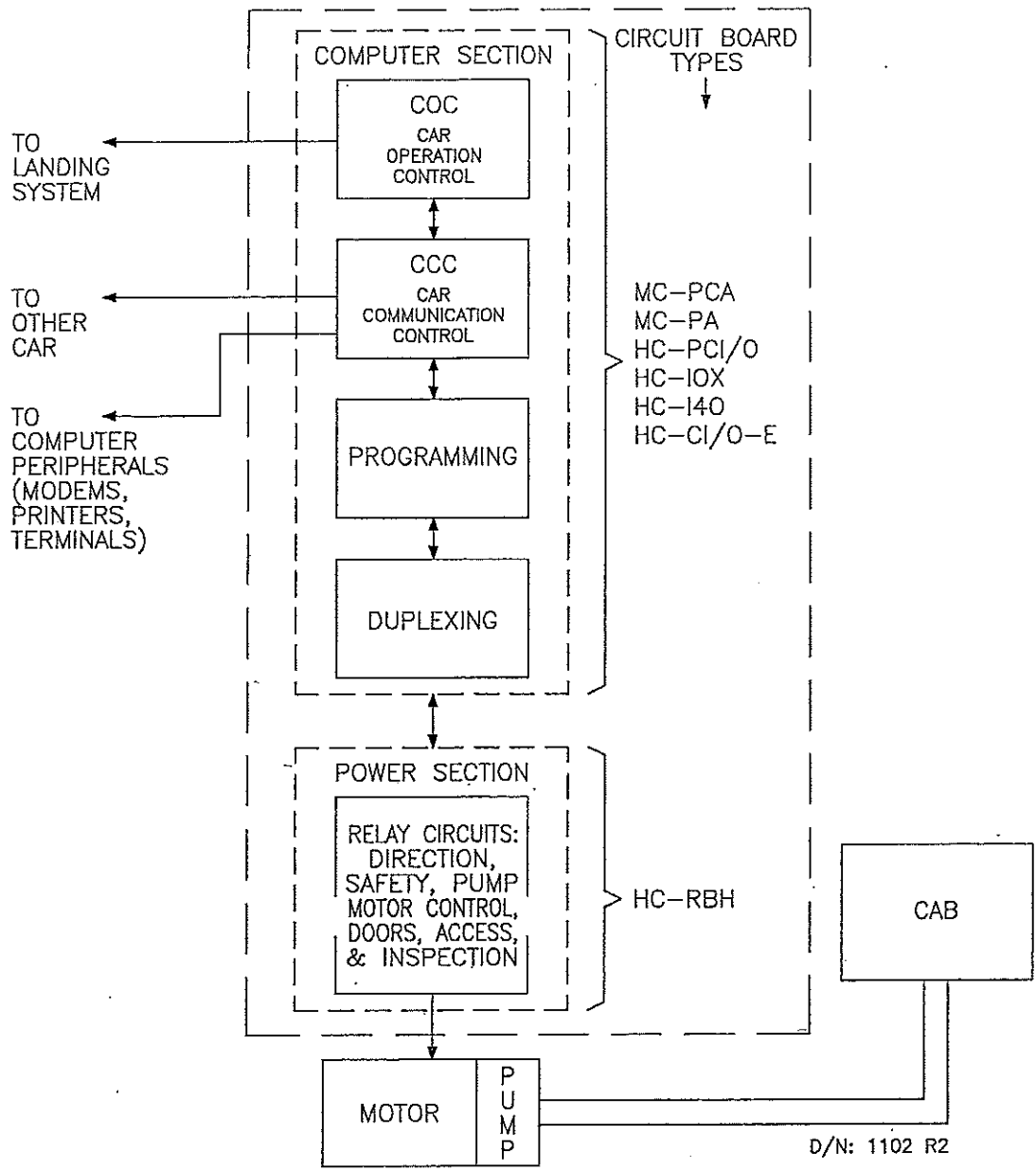

The heart of the COC is the HC-RBH (Main Relay) board, which makes it possible to move the car without computers and satisfies code-required safety functions and redundant relay backup functions. All computer functions can fail in an ON condition and the car will not move if the door lock circuits are not closed. Except for calls, most of the individual elevator inputs and outputs are handled through the Main Relay board and are routed to the HC-PCI/O board, which is the main interface to the computer.

Provisions for 4 position indicator outputs are on the HC-PCI/O board. If additional position indicators are required, HC-CI/O-E boards are added as required. If independent (walk-through) rear doors are required, the HC-RD board acts as the interface between the computer and the Rear Door Relay board, which handles all functions associated with the rear doors. Some additional inputs and outputs such as load weighers are handled through the HC-PCI/O board. Car calls and hall calls are interfaced to the computer through the HC-PCI/O board and HC-CI/O-E boards, which can handle up to 4 landings per board. Therefore, all the input/output boards (HC-PCI/O, HC-RD, HC-IOX, HC-I40 and HC-CI/O-E) act as the interface between the

MC-PCA Main Computer board and the user. These input/output boards are linked to the HC-PCI/O board through a ribbon cable. A connector on the back of the MC-PCA board plugs into the HC-PCI/O board. The MC-PCA board contains the main elevator logic program.

### 1.2.2 CAR COMMUNICATION CONTROL (CCC)

The Car Communication Control (CCC) coordinates communication between the individual car controllers in a duplex configuration, as well as peripheral devices such as modems, printers, CRT terminals, etc. These functions are performed by the MC-PCA Main Computer board.

### 1.2.3 PROGRAMMING AND DIAGNOSTICS TOOLS

The PHC is a versatile hydraulic controller and is compatible with most applications. This means it allows the user to customize the controller to the building requirements after the unit has been installed. The Programming Tool is part of the processing unit (MC-PCA computer board). The list of all of the programmable functions and variables are provided in Section 5 of this manual.

### 1.2.4 DUPLEXING

Each car is capable of seeing the hall calls and at any time performing the duplexing functions, but only one of the cars can process the hall calls and make hall call assignments. If the car that is performing the duplexing operation goes out of service, the other car will take over the hall call registration and assignment.

---

## 1.3 LANDING SYSTEM CONTROL BOX

The Landing System is designed to be mounted on the car top. There are two types of landing systems that can be used with Series PHC controllers: LS-STAN and LS-QUTE.

**LS-STAN** - The LS-STAN is the standard landing system. The car top control box uses VS-1A infrared proximity switches to sense vanes that are mounted in the hoistway (Figure 1.10).

**LS-QUTE** - The LS-QUTE is a tape-and-magnet-operated landing system, with a three inch wide steel tape mounted in the hoistway (Figure 1.11). The car top control box has a floating head that slides on the steel tape, and magnetic sensors for slow down, STU, STD, ISTU, ISTD, LU, LD and DZ. Optional absolute floor encoding is available. Refer to Appendix E, LS-QUTE Landing System Assembly Drawings, for more information.

FIGURE 1.10 LS-STAN Car Top Control Box

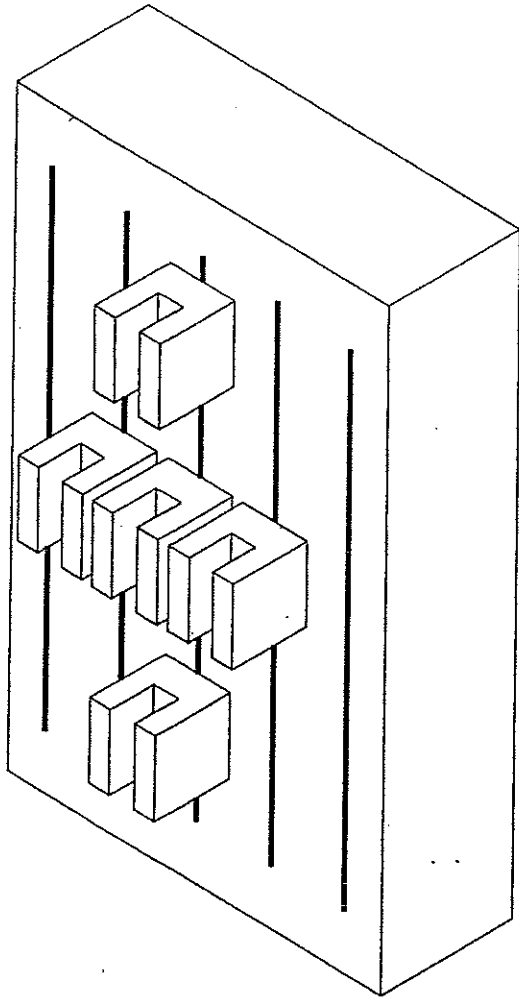

D/N: 1105

FIGURE 1.11 LS-QUTE Car Top Control Box

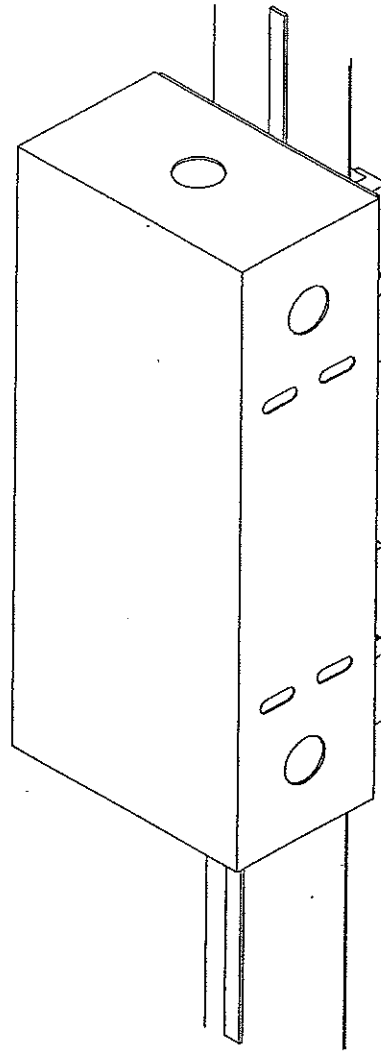

---

# SECTION 2

## INSTALLATION

---

### 2.0 GENERAL INFORMATION

This section contains important recommendations and instructions for site selection, environmental considerations, installation guidelines and other factors that will help ensure a successful installation.

#### 2.0.1 SITE SELECTION

To help choose a proper location for the controller, consider the following factors:

- Provide adequate working space for comfort and efficiency.
- Mount the controller in a logical location, taking into consideration the location of other equipment in the machine room and proper routing of electrical power and control wiring. Note that MCE controllers do not require rear access.
- Do not install the controller in a hazardous location.
- Provide adequate space for future expansion, if possible.
- If any areas in the machine room are subject to vibration, they should be avoided or reinforced to prevent the controller from being adversely affected.
- Provide adequate lighting for the control cabinets and machines in the machine room. Providing a good working space such as a workbench or table is recommended.

#### 2.0.2 ENVIRONMENTAL CONSIDERATIONS

There are some important environmental considerations which when observed, increase the longevity of the elevator equipment and reduce maintenance requirements. These are:

- Provide an ambient temperature that will not exceed 32° to 104° F (0° to 40° C). Operation at higher temperatures is possible, but not recommended, because it will shorten the life of the equipment. Adequate ventilation and possibly air conditioning may be required.
- The air in the machine room should be free of excessive dust, corrosive elements or excessive moisture to avoid condensation. A NEMA 4 or NEMA 12 enclosure would help meet these requirements. If open windows exist in the machine room, locate the controller away from the windows so that severe weather does not damage the equipment.
- High levels of radio frequency (RF) radiation from nearby sources may cause interference to the computers and other parts of the control system. Using hand-held communication devices in close proximity to the computers may also cause interference.
- Power line fluctuation should not be greater than +/-10%.

### 2.0.3 RECOMMENDED TOOLS AND TEST EQUIPMENT

For proper installation, use the following tools and test equipment:

- A digital multimeter, Fluke series 75, 76, 77 or equivalent
- A hand-held tachometer
- A clamp-on AC ammeter
- Hand-held radios
- A telephone
- Test weights
- Pressure gauge
- Soldering tools, a flashlight and an MCE screwdriver (provided with controller).

### 2.0.4 THE WIRING PRINTS

Become familiar with the following information as well as the wiring prints provided with this control system.

**DRAWING NUMBER FORMAT** - Each print has a drawing number indicated in the title block. The drawing number is comprised of the job number, car number and page number (see example). In this manual the drawings will often be referred to by the last digit of the drawing number (page number). The following is the drawing number format currently in use.

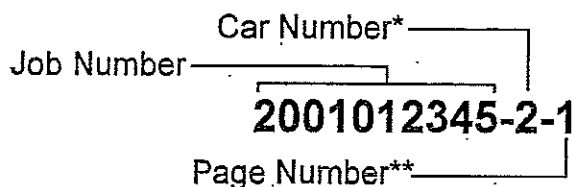

\* Car Number "G" = Group Controller

\*\* Page Number "D" = Drive page

\*\* an "X" after the page number = auxiliary page



**NOTE: DRAWING NAME** - Some drawings have a drawing name directly above the title block or at the top of the drawing. The drawing name may be used to refer to a particular drawing.

**NOMENCLATURE** - The following is an example of the schematic symbols use to indicate that a signal either enters or exits a PC board.

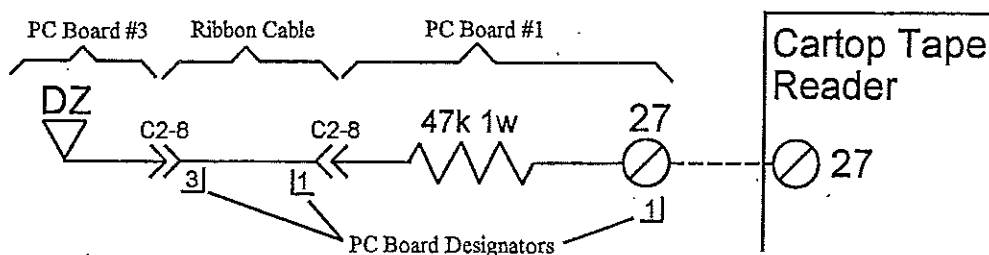

A listing of PC boards and their designator numbers plus other schematic symbols used in the wiring prints can be found at the beginning of the Job Prints and in Appendix B of this manual.

- Become familiar with the "Elevator Car Wiring Print" drawing number -1.
- Become familiar with the "Elevator Hoistway Wiring Print" drawing number -2.
- Become familiar with page -7 of the job prints for duplex interconnect wiring if this application is duplexed.
- The power connections and power supplies are shown in drawing number -3.
- Review any additional wiring diagrams and details.
- The remainder of the job prints are detailed drawings of the HMC-1000-PHC programmable hydraulic control system.
- A specific part of a schematic may be referenced by the Area Number, which is found at the left-hand margin of the schematic.

## 2.1 CONTROLLER INSTALLATION

Mount the controller securely to the machine room wall or other appropriate location and cut holes to install a raceway or conduit to permit the routing of wires into the cabinet. Note that the standard MCE control cabinet does not require rear access.



**CAUTION:** Do not allow any metal chips or drill shavings to fall into the electronics.

### 2.1.1 CONTROLLER WIRING GUIDELINES

- PC boards can be easily damaged by Electrostatic Discharge (ESD). Use a properly grounded wrist strap when touching the PC boards.

Do not touch PC Boards unless you are properly grounded.

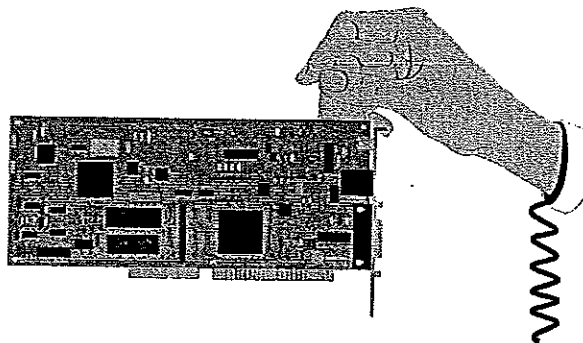
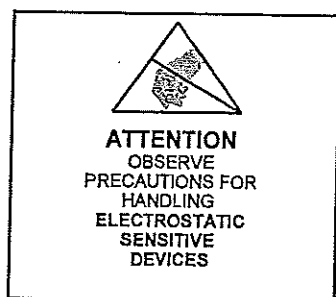

- Bring wires in from a location that allows the use of the wiring duct inside the controller to route the wires. The terminals are found conveniently near wiring ducts.
- When routing field and/or power wiring, avoid the *left* side of the HC-CI/O-E and HC-PCI/O board.

- d. When connecting wires to the controller, connect the wires according to the hoistway and car wiring diagrams.
- e. If the car is part of a duplex system, there are a number of details relating to the wiring of the interconnects between the individual cars. They are as follows:
  1. A separate conduit or wiring trough must be provided for the high-speed serial link between the MC-PCA computers in each controller cabinet.
  2. The wiring details for the high-speed communication link are fully detailed in the drawing titled "Instructions for Connection of High Speed Communication Cables" in the job prints. Follow these instructions exactly. Again, note the requirement for routing the high-speed interconnect cables through a separate conduit or wiring trough.
  3. If applicable, also wire according to the drawing titled "Duplex Interconnects to Individual Car Cabinets" in the job prints. Make sure to ground all of the cabinets according to Section 2.2.1.

---

## 2.2 GENERAL WIRING GUIDELINES

Basic wiring practices and grounding requirements are discussed in this section.

### 2.2.1 GROUND WIRING

To obtain proper grounding, quality wiring materials and methods should be used.

All grounding in the elevator system must conform to all applicable codes. Proper grounding is essential for system safety and helps to reduce noise-induced problems. The following are some grounding guidelines:

- The grounding wire to the equipment cabinet should be as large as, or larger than, the primary AC power feeders for the controller and should be as short as possible.
- The grounding between equipment cabinets may be branching or a daisy chain, but the wire must terminate at the last controller and NOT loop back (see Figure 2.1).

---

**FIGURE 2.1** *Ground Wiring to Controller Cabinets*

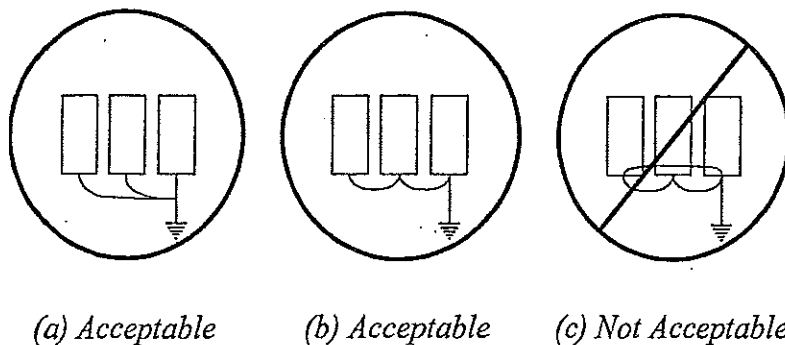

- Direct solid grounding must be provided in the machine room to properly ground the controller and the motor. Indirect grounding, such as the building structure or a water pipe, may not provide proper grounding and could act as an antenna radiating RFI



noise, thus, disturbing sensitive equipment in the building. Improper grounding may also render an RFI filter ineffective.

- The conduit containing the AC power feeders must not be used for grounding.

## 2.2.2 MAIN AC POWER

Main AC power supply wiring size must be determined by the electrical contractor. Proper motor branch circuit protection must be provided according to applicable electrical codes in the form of a fused disconnect or circuit breaker. Each disconnect or breaker must be clearly labeled with the elevator number.

## 2.2.3 PUMP MOTOR WIRING

Connect the pump motor for the proper configuration shown on the wiring diagrams. Connect the pump motor leads to the proper terminals on the controller.

## 2.2.4 PHASE MONITOR INSTALLATION (SLA SERIES PHASE MONITORS)

### ***BE SURE THE POWER IS OFF PRIOR TO INSTALLING THE PHASE MONITOR***

1. Mount the unit or applicable socket in or near the control panel of the equipment to be protected.
2. If applicable, turn the adjustment dial to minimum (CCW).
3. Connect wires from the fused 3 phase line voltage to the proper terminals as shown in the configuration diagrams (Figure 2.2). In WYE connected systems, connection to neutral wires is not required. Do not wire output contacts until step 9.
4. Turn power ON. The internal output relay should energize and the LED (if applicable) should glow. On manual reset models, depress reset button to energize. On models without an LED, an audible "click" should be heard when the internal output relay energizes. A continuity tester can be placed across the normally open contacts to check operation on all models.
5. If the internal output relay and LED do not energize, turn power OFF and swap any two (2) of the three (3) input wires. This corrects the phase sequence if the monitor was connected in the reverse rotation.
6. Turn power ON. When the internal output relay and LED energize, the phase sequence is correct and the voltage on all three phases are above the minimum voltage set point. If your monitor is a fixed voltage device, skip to Step 9.
7. Select the proper voltage trip point. *Slowly* rotate the adjustment dial clockwise until the LED extinguishes and the internal output relay de-energizes.  
  
Note: Some high line and unloaded conditions may prevent maximum (CW) adjustment beyond the point where the LED extinguishes and the internal output relay de-energizes. Leave the adjustment at the maximum (CW) position and proceed to Step 8 Note.
8. Next *slowly* rotate the adjustment dial counter clockwise until the LED stays on steady state and/or the internal output relay energizes. This procedure assures that the monitor is set at your exact line-to-line voltage.

Note: It may be necessary to slightly lower the adjustment dial (CCW) to prevent nuisance tripping. CAUTION! Lowering the adjustment dial setting more than 10-12°(CCW) below the precise set point may interfere with proper operation.

9. Turn power OFF. Refer to the proper configuration (Figure 2.2) for output contact connections.

**FIGURE 2.2** SLA Series Phase Monitor Wiring Diagrams

Wiring Diagrams

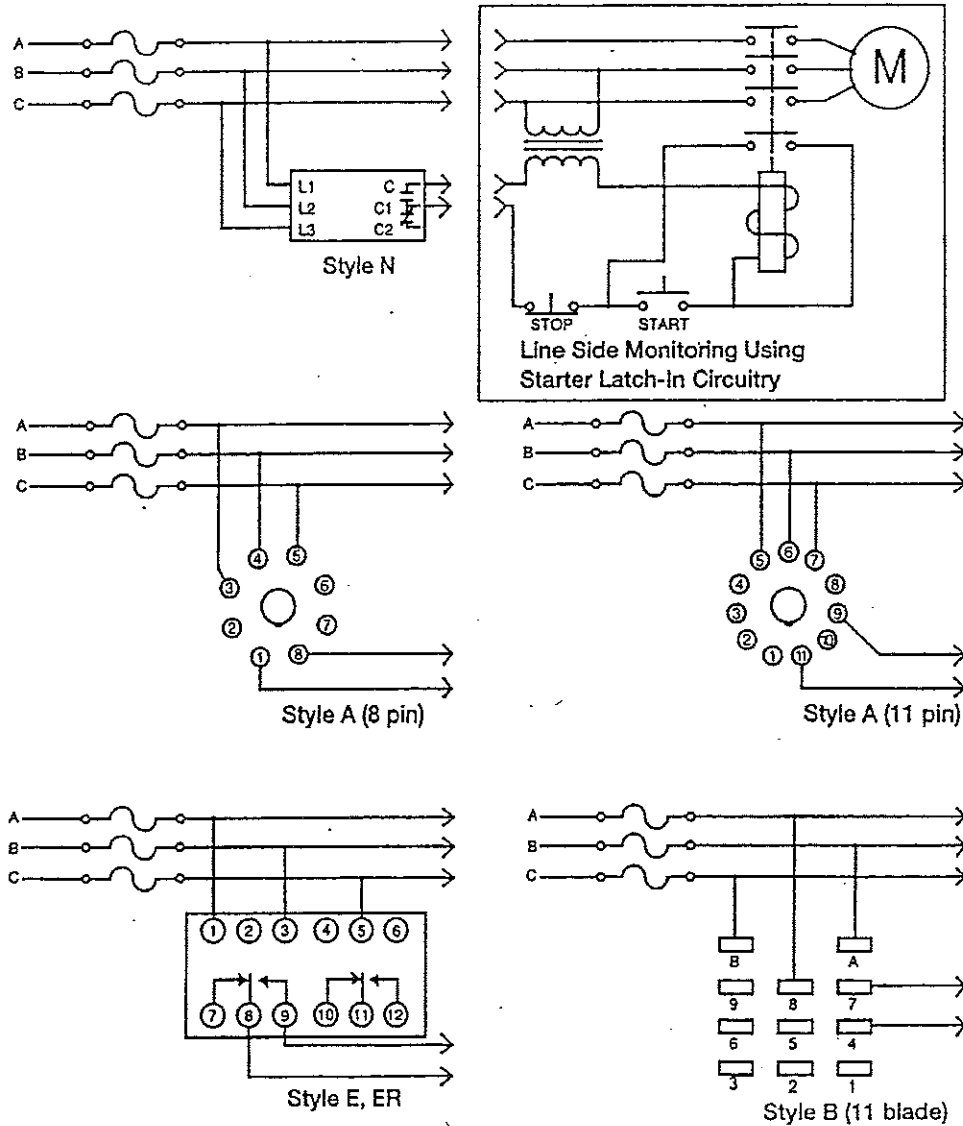

10. After proper connections have been made, turn power ON. The internal output relay will energize thus allowing the monitored load to become active.

The equipment is now protected against low voltage, phase reversal and phase loss.

## 2.3 HOISTWAY CONTROL EQUIPMENT INSTALLATION

This section covers the recommended procedures for installing the landing system, terminal slowdown switches, directional limit switches, hoistway access switches (if required), the hoistway access limit switch, and the emergency terminal slowdown switch.

**2.3.1 INSTALLING THE LANDING SYSTEM** - Refer to the installation drawings for the type of landing system provided.

### 2.3.2 INSTALLING THE HOISTWAY LIMIT SWITCHES

- a. The terminal landing slowdown switches should be installed and adjusted to open approximately one inch beyond the point where a normal slowdown is initiated.
- b. The direction limit switches should be installed and adjusted to open approximately one inch beyond the terminal landings.
- c. The emergency terminal slowdown switch (if required) should open after the direction limit is open, but before striking the stop ring. Install and adjust the switch where it will not interfere with Inspection or Automatic operation while leveling or releveling. It must also be adjusted to achieve the required operation according to the applicable elevator code.
- d. Ensure that the cam that operates the slowdown and limit switches maintains the terminal slowdown switch open until the direction limit switch and emergency terminal slowdown switches (if required) are open.
- e. Ensure that the terminal slowdown, direction limit and emergency terminal slowdown switches are held open for the entire runby or overtravel of the elevator.
- f. The hoistway access limit switch (if required) should be installed and adjusted to open and stop the elevator (in the down direction), when the top of the elevator is approximately level with the top landing (when the top hoistway access switch is activated while on Access or Inspection operation).

**2.3.3 INSTALLING THE LANDING SYSTEM CONTROL BOX (LS-QUTE)** - Refer to the drawings in the job prints.

- The location for the landing system box should have already been selected.
- Holes are available on both sides and on the bottom of the landing system box for mounting to any support brackets or structural channels. The mounting of the box should be very firm and solid so that knocking it out of alignment should be difficult. Use 1/4-20 hardware.
- To install the tape into the tape guides on the LS-QUTE landing system box, remove the 2 thumbscrews on the 2 guide assemblies, insert the tape and reinstall the guides with the thumbscrews (tighten firmly). If the installation has the LS-QUTE car top selector with the additional sensor bracket on the rear of the tape, first remove the three 8-32 screws holding the protective 1" wide channel. This channel covers the back of the Door Zone sensors on the upper tape guide bracket. Remove the single standoff that is in the way of the thumbscrew holding the tape guide. Remove the thumbscrews holding the upper and lower tape guides, insert the tape, and reinstall the guides with

the thumbscrews (tighten firmly). Reinstall the standoff (do not over-tighten) and the protective channel.

- After inserting the steel tape into the tape guides, check the location of the landing system box. The car should be at the top of the hoistway to make it easier to see if the alignment is causing any stress or binding on the tape guides. Make sure that the box is *vertical* and plumb with the tape. This allows for easy tape movement and avoids excessive wear on the tape guides (using a level is helpful). *Be careful* so as to avoid premature failure of the tape guides.
- Move the elevator to the top and bottom of the hoistway to check for smooth tape movement and to make sure that there is no excessive pressure on the tape guides. Correct any problems immediately.

#### **2.3.4 INSTALLING THE MAGNETIC STRIPS ON THE STEEL TAPE**

- a. Carefully, read and follow the Magnet Installation instructions in the job prints, but read the rest of these instructions before proceeding.
- b. Before installing the magnets, clean the steel tape thoroughly with an appropriate solvent. No oil should be left on the tape as it will interfere with the adhesive backing on the magnets.
- c. There are normally five lanes of magnets installed on the side of the tape facing the car. One lane consists of only the LU/DZ/LD and requires that a 6-inch magnet be installed at each floor. The other lanes have magnets which initiate slow downs.
- d. If the installation has rear doors, it may have an LS-QUTE landing system which has additional Door Zone sensors on the rear of the upper tape guide assembly. Follow the Magnet Installation instructions in the job prints and install the front and rear Door Zone magnets on the steel tape as shown.

#### **2.3.5 DOOR OPERATOR DIODE INSTALLATION (IF USED)**

Certain door operators, such as G.A.L. models MOM or MOH, require the installation of diodes in the door operator on the car top. See the drawing titled "Elevator Car Wiring Print" in the job prints for any special instructions regarding these diodes.

# SECTION 3

## START-UP SEQUENCE

### 3.0 GENERAL INFORMATION

This section discusses preparing the car to run on Inspection operation and covers the sequence of applying power to the controller and its associated components and verifying proper phase sequence and motor rotation. It also covers completing the initial adjustment of the system to get basic car movement on Inspection operation.

### 3.1 GROUND CHECK

Do a ground test before powering up the system. Set the meter on the RX1 range (100 to 200 ohm range). Take all measurements with respect to the 1-bus, which is also referred to as the *system common* elsewhere in this manual.



**NOTE:** A ground is defined as a resistance of less than 100 ohms.

- a. Remove the F4 fuse in the individual car controller cabinet. If the system is a duplex and/or fire recall system, consult the schematics and remove the fuse that powers terminals 2H (Hall Call Power) and/or 2F (Fire Recall System). Check for grounds on the 2H and 2F terminals.
- b. Check for grounds on all terminals on the bottom of the HC-RBH board (Main Relay board). Terminal 89 is the only terminal that *should be* grounded.
- c. Check for grounds on all terminals on the HC-PCI/O (and HC-CI/O-E boards, if present).
- d. Check for grounds on terminals F1, F2, A1, A2, and D5 if a G.A.L. MOD door operator is provided (remove door fuses F7 and F8). For other door operators, consult the job prints as to which fuses to remove and check the appropriate terminals for grounds.

### 3.2 BEFORE APPLYING POWER



**NOTE:** MGE's HMC 1000 Series PHC is designed to operate on Inspection and Access without the computers hooked up during start-up.



**NOTE:** These instructions assume adequate electrical troubleshooting experience. Follow the procedure carefully. If the elevator does not respond correctly, check the circuits according to your ability. Proceed cautiously. Read these instructions all the way through to become familiar with the procedure before starting the work.

- a. Unplug the screw terminal blocks from the HC-PCI/O and any HC-IOX or HC-CI/O-E boards by moving the blocks toward the right. This is done to avoid damaging the boards by an accidental shorting of output devices to one of the power buses (terminals 2, 3, or 4) during the first powering up of the system.
- b. With all power OFF, remove one side of the ribbon cable connecting the HC-PCI/O board at connector C1, by pushing the two latches on C1 open and removing the ribbon cable.
- c. In the following instructions, it is assumed that all hoistway doors are closed, but not necessarily locked, and all hoistway and machine room wiring is complete. The hoistway limit switches *must* be adjusted to the manufacturer's specifications. Correct any malfunction before continuing further.

---

### 3.3 APPLYING POWER

#### 3.3.1 INITIAL ADJUSTMENTS AND POWER PHASING

- a. Install a jumper wire between terminal 4 and 8 on the HC-RBH board to **override the gate switch and the door locks**.
- b. Ensure that the Soft Stop jumper (below the AA relay) is in the OFF position by *carefully* pulling it straight out from the board and plugging it back in correctly. It may be tight, so be careful.
- c. If a field wire is connected to terminal 59 on the HC-RBH board, temporarily remove the wire, label and insulate it. This will disable the Car Top Inspection switch.
- d. Turn ON power to the controller by closing the machine room disconnect switch.
- e. Check pump motor rotation by briefly pushing in the starter (or WYE switch, if there is WYE-DELTA starting) and note motor rotation. If the rotation is not correct, reverse any two of the three leads at the main disconnect switch. If an RP (Reverse Phase) sensor is provided and the sensor contact does not close when power is applied to the controller (indicated by a light on the sensor that comes on when phase rotation is correct), then 2 of the 3 AC wires that connect to the RP sensor may have to be reversed. Some contactors may not make up when activated by hand. Use push-button relay AA on the HC-RBH board to check rotation.
- f. Since the C1 connector between the HC-RBH and the HC-PCI/O boards has already been disconnected, the LCD display should show that the safety string is open by flashing **SAFETY** in the upper right-hand corner of the display. The SAFETY ON light will also be off.
- g. On the HC-RBH Main Relay board, place the INSP. SPEED HI-LO switch in the LO position and adjust the valves for proper low speed operation.



**NOTE:** The HMC-1000 Controller is equipped with an INSP. SPEED HI-LO switch to allow the car to be run at either high or low speed on car top Inspection or hoistway Access operation. For these operations the car should NOT be run at high speed if the contract speed is greater than 150 fpm.

### 3.3.2 MOVING THE ELEVATOR ON INSPECTION

- a. Turn OFF power at the main disconnect and reinstall fuses F4, F7 and F8 (and any other fuses that may have been removed during the ground check).
- b. Turn the Relay Panel Inspection ON/OFF switch to the ON position (this switch is found on the left-hand side of the HC-RBH Relay board). Place a jumper between terminal 18 and 59. This will allow relay RPI to pick (once the power is turned back on) and permit the use of the Relay Panel Inspection UP/DN switch.
- c. Turn ON the power at the main disconnect. If the LCD display reads **-SAFETY-** the car will not run. The LCD display should indicate **-INSPECTION-** and the LEDs Safety On, Doors Locked and Inspection Access on the PCA-0A board should be ON.
- d. Move the car up and down with the Relay Panel Inspection UP/DN switch. The following relays must pick in the *up* direction: AA, RPI, SAF, Y, BB and DELTA. If AA and BB are not picked, check to see that relays IN1 and IN2 have dropped out (de-energized). If no relays are picked, check the F4 fuse and check to see that there is 120VAC between terminals 1 and 2. If SAF is picked and AA is not, check the starter overload contacts. If SAF is not picked, briefly jumper 2 to 20 (**bypass the safety string**). If SAF picks with the jumper, then the trouble is in the safety string. If SAF still does not pick, check the RP sensor again.
- e. Adjust the BB timer potentiometer on the HC-RBH board to transfer from WYE to DELTA just as the pump motor reaches maximum rpm from a dead stop.
- f. Adjust the valves for proper Inspection operation.

### 3.3.3 PREPARING THE CAR TO RUN ON AUTOMATIC OPERATION

- a. Turn OFF the power at the main disconnect.
- b. Complete and finalize installation and all wiring. Hook up the field wires for the car calls, hall calls and PIs into their respective terminals (remember that the plug-in terminals have yet to be inserted into the boards). Connect one probe of the meter to the 1-bus and with the other probe, check all of the call and PI terminals for shorts to ground. Connect the common probe of the meter to the 2, 3 and 4 buses sequentially while checking for shorts to the call and PI terminals.
- c. Turn ON power at the main disconnect and probe the call and PI terminals again. This time, check to make sure that there is no voltage present on any of the PI terminals with respect to the 1-bus. Jumper each of the call terminals one-by-one to ground or terminal 1. Verify that no fuses blow, especially F4. Turn OFF the power at the main disconnect.
- d. Plug the call and PI terminals back into the appropriate boards.
- e. Place all switches on Normal and put the Car Top Inspection switch on Inspection. Remove the jumper from terminal 18 to 59 and put the field wire back into terminal 59 on the HC-RBH board. With the power on, verify that no AC voltage exists on terminal 59 with respect to the 1-bus. Note that Car Top Inspection prevents Relay Panel Inspection operation.

---

### 3.4 PREPARATION FOR FINAL ADJUSTMENT

- a. The door operator must be operating properly with all door equipment (clutches, rollers, etc.) properly adjusted with the correct running clearances. Check the job prints to make sure that all instructions have been followed regarding the installation of diodes on the door operator (especially for G.A.L. door operators).
- b. Make sure the car doors are closed and that all hoistway doors have been closed and locked. Run the car on Inspection through the hoistway to make sure that the hoistway is completely clear. Check to see that the landing system has been installed according to the installation instructions. Place the car at the bottom of the hoistway.
- c. Turn the TEST/NORM switch on the HC-RBH Relay board in the TEST position.



# SECTION 4

## FINAL ADJUSTMENT

### 4.0 GENERAL INFORMATION

At this point all of the steps in Section 3 should have been completed. Please read Section 5 before proceeding: it explains the adjustment and troubleshooting tools available with the computer. This section contains important recommendations and instructions for operating the elevator on Automatic operation.

### 4.1 RUNNING ON AUTOMATIC OPERATION

Move the car to the bottom landing on Inspection operation and turn the power OFF. Reinsert connector C1 into receptacle C1 on the HC-PCI/O board (if previously removed).



**NOTE:** Pin 1 on both the ribbon cable connector and the header on the HC-PCI/O board must match. These are designated with arrows on the connector and header. Press the connector in until the latches snap, securing the connector in place.

- a. If the door operator is not working, pull the door fuses and close the doors so that the door clutch will not hit any of the door lock rollers. Take whatever steps are necessary to keep the installation safe, but make sure that the car top is still accessible after closing all of the doors. Turn ON the AC power to the elevator.
- b. Temporarily take the car off of Inspection operation. If the LCD display does not show Test Mode, see what message is being displayed and correct the problem. For example, if the indicators show that the car is on Fire Service Phase 1, a jumper must be connected between terminal 2 on the back plate and terminal 38 on the HC-RBH board in order to run the car on Normal operation. Remove the jumper once the Fire Service input is brought into the controller. Place the car on Inspection.



**NOTE:** If the car is not completely wired (temporary), check the following:

- wire removed from panel mount terminal DCL
- wire removed from terminal 47 on the HC-RBH board
- jumper from 2 bus to terminal 36 on the HC-RBH board
- jumper from 2 bus to terminal 38 on the HC-RBH board
- jumper from 2 bus to panel mount terminal EPI (if present)

#### 4.1.1 DIAGNOSTIC MESSAGES AND INPUT/OUTPUT SIGNALS

To speed up final adjustment and troubleshooting, become familiar with the Error Status Messages (Table 5.2) and Input/Output signals (Flags and Variables, Tables 5.3 and 5.4).



**NOTE:** Read Section 5.1: *The MC-PCA Computer Panel - Your Tool for Programming, Diagnostics and Data Communication* and Section 5.3: *Diagnostic Mode*.

**ON-BOARD DIAGNOSTICS** - When the Elevator Controller's Computer (MC-PCA) is in the DIAGNOSTIC MODE, with switches F1 - F8 in the down position, the LCD display provides a description of normal and abnormal conditions. When the LCD displays NORMAL, in the car status field, the system is ready for normal operation. A complete listing of the status and error messages, their meaning, probable cause and needed response are found in Table 5.2, Error Status Messages and Response Chart.

The computer displays abnormal conditions in the same priority that the computer evaluates them. For example, if the safety circuit is open and the system is also on Fire Service, the computer will first show that the safety circuit is open and will expect this problem to be corrected first. When the safety circuit problem has been corrected and the computer has recognized the safety input, the diagnostics will then show the Fire Service Indication. After successfully bringing in the Fire Service input, the computer will then show NORMAL on the LCD display, provided that the system is not on some other function such as Independent Service or Cartop Inspection operation. The display will show NORMAL only if everything is normal. If the LCD display is showing any other message, an abnormal condition exists.

#### 4.1.2 A FEW WORDS ABOUT ABSOLUTE FLOOR ENCODING

Absolute floor encoding is an option which allows the controller to read encoding vanes or magnets at each landing and thereby identify the floor. If the absolute floor encoding option is provided, the behavior of the car, when power is turned ON, is different than without absolute floor encoding.

**JOBS WITHOUT ABSOLUTE FLOOR ENCODING** - If the car is in the middle of the hoistway when power is turned ON, the controller will not know where the car is and must send the car to the bottom landing to get in step with the floor Position Indicator. It does so by generating an internal BFD (Bottom Floor Demand) flag in the computer. When the BFD flag is present, no car calls will be accepted until the car reaches the bottom terminal. The BFD flag will be cleared when the DSD (Down Slow Down) switch has opened (dropping power to terminal 13) and if DZ (Door Zone) and DLK (Door Locked) are both active. If the car is on Automatic Operation, and if a home floor has been designated, the car will move to the home landing at this time.

If the car is put on Relay Panel Inspection or Cartop Inspection operation and then is returned to Automatic operation, if the car is not at a terminal landing, the controller will create the BFD flag and will act as described above. If the BFD flag is present, and the TEST/NORMAL switch is on TEST, it will be necessary to place a jumper between terminals 2 and 45 (Door Close input) to move the car. It may be necessary to hold the jumper on the terminals for several seconds.

**JOBS WITH ABSOLUTE FLOOR ENCODING** - If the car is not at a landing when power is turned ON, the controller will generate a down direction command and the car will move toward the closest landing, provided that all abnormal conditions have been corrected. When the car reaches a landing and is within the Door Zone (relay DZ picked) with leveling completed (relays LU and LD not picked) the controller reads the floor code vanes or magnets and corrects the Position Indicator. If the car is on Automatic Operation, and if a home floor has been designated, the car will move to the home landing at this time. If the car is at a landing, within the Door Zone (relay DZ picked) with leveling completed (relays LU and LD not picked) when AC power is turned ON, the controller will read the floor code vanes or magnets at the landing and correct the Position Indicator. Again, if a home floor has been designated the car will move to this landing to park.

### 4.1.3 REGISTERING CAR CALLS

In the process of making final adjustments to the controller, periodically you will be asked to register car calls. A call or series of calls can be registered at the controller by momentarily placing a jumper between terminal 1 (system common) and the desired car call terminal or terminals on the HC-PCI/O or HC-CI/O-E board, and then between terminal 2 and terminal 45 to allow the car to travel to each call. The car may move immediately after the first call is placed, or it may wait several seconds before moving.



**CAUTION:** The call terminals on the HC-PCI/O and HC-CI/O-E board should *never* be connected to any of the power terminals (such as 2, 3, 4, etc.). If this happens and the call is turned on, it will blow the resistor-fuse or triac which plugs into the board. Later versions of these boards may have plug-in zener diodes. These parts are designed to be field replaceable and spares are provided in unused positions on the board, or are available from MCE. **DO NOT JUMPER THESE PLUG-IN COMPONENTS AS IT MAY DESTROY THE BOARD OR OTHER CONTROLLER COMPONENTS.** If any of these components should blow, **FIND OUT WHY** instead of constantly replacing them, as the constant faults can eventually damage the board.

### 4.1.4 TEST MODE OPERATION

The purpose of TEST mode is to allow easy and convenient operation of the car so that the final adjustments can be made without cycling the doors. When the elevator is operated in the TEST mode, the elevator doors do not open. The door open relays are disconnected automatically during TEST mode operation.

The car is put into TEST mode by placing the TEST/NORMAL switch on the HC-RB4-SCR (Main Relay) board in the TEST position. Note that when the TEST/NORMAL switch is in the TEST position, it puts the car into Test Mode, provided that the Car Top Inspection and Relay Panel Inspection switches are in the OFF or normal positions. In that case, the LCD should be showing TEST MODE and not NORMAL. If the expected indication is not displayed, check to see what message is being displayed and correct the problem. Operation while in TEST mode should be easy to understand by knowing the following:

- a. Every time the car stops, a non-interference timer *must* elapse before the car can move again (the car will not move unless there is another car call). Note that after the timer has elapsed, the car will move immediately as soon as the next car call is placed (the car will not move if the system is a single button collective system and there is no jumper from terminal 2 to terminal 45). Placing a car call right after the car stops will require the non-interference timer to elapse before the car can move again.
- b. Simply having one or more car calls registered will not necessarily cause the car to move. It will be necessary to jumper terminal 2 to terminal 45 to create a Door Close Button input to get the car to move. If the car is not a single button collective but is a selective-collective, the jumper from terminal 2 to 45 will not be necessary. Leave a jumper connected from terminal 1 to the last car call in the line of calls that have been placed. This will create a constant pressure signal on the car call which is an alternate means of creating a Door Close Button signal to get a car that is on Independent Service to leave the landing. However, the jumper from terminal 2 to terminal 45 may be more convenient.

- c. If a jumper from terminal 1 is touched to the car call input for the floor where the car is located, it will reestablish the non-interference timer and it must elapse before the car can move again.
- d. If the elevator is trying to level, it will not pick high speed and leave the landing until it has completed the leveling process. Drive Unit speed adjustments and direction limits at terminal landings may cause this problem.
- e. If any of the inputs that open the door are active (Safety Edge On, Photo Eye On, Car Call input grounded to 1 for the floor matching the Position Indicator, etc.) the car will not leave the landing.
- f. Both slowdown switch inputs (terminals 11 and 13) should *never* be inactive at the same time when the doors are closed and locked and the safety circuit is closed.

#### 4.1.5 SWITCHING TO AUTOMATIC OPERATION

- a. Place the car on Inspection operation.
- b. Move the car to the bottom terminal landing. Check to see if the DZ relay is picked. If not, move the car on Inspection to place it in the Door Zone.
- c. Place the Relay Panel Inspection switch in the OFF position. If the car is not at a landing, it will move to a landing. If the car is at a landing but not in the door zone, either the LU or LD relay should pick and the car should perform a relevel. If the relevel is not successful, check the following:
  - If the LD relay is picked, but the brake and other relays are not, the down direction limit switch may be preventing the leveling down operation.
  - If the car is trying to level, it will not leave the landing for a call until the leveling is complete. Move the limit switch if necessary.

The Status Indicator lights should now display the indication for Independent Service operation. At this time the Position Indicator should match the actual car location. Note that all of the Position Indicators and direction arrows are conveniently displayed on the controller. All the calls are also displayed on the controller.

---

## 4.2 FINAL ADJUSTMENTS

### 4.2.1 DOOR OPERATOR ADJUSTMENTS

Install the fuses for the door operator(s) and complete the final adjustments. Doors can be opened at 3" before the floor or at the floor (non-pre-opening option). Hydraulic elevators are usually set up to open the doors only after the car stops, but pre-opening is available. Contact MCE Customer Service.

### 4.2.2 HYDRAULIC VALVES

Adjust hydraulic valves for proper speed, acceleration, deceleration, etc. and check contract speed. A hardware timer on the HC-RBH board automatically provides pump motor overrun for Soft Stop operation. Ensure that the Soft Stop jumper is in the ON position for it to be on and in the OFF position for it to be off.

#### 4.2.3 SLOWDOWN AND LIMIT SWITCHES

Disconnect the stepping switch inputs (for 3 or more landings) and verify proper operation of all slowdown and limit switches for slowing and stopping the car at both terminal landings.

#### 4.2.4 HALL CALLS

Place hall calls for all of the landings and make sure all hall calls function properly.

#### 4.2.5 OPTIONS

Verify the operation of the following options: Independent Service, Fire Return Phase 1 (Main Floor and Alternate Floor operation, if provided), Fire Phase II In-Car operation, and any other options provided.

#### 4.2.6 DOOR OPEN/CLOSE PROTECTION

The elevator controller is provided with door open protection and door close protection. If the doors do not open after several seconds, the car will give up and continue to the next call. After the car starts to close the doors and the doors do not lock, it will recycle the doors open and attempt to close the doors three times before a DLK fail error.

#### 4.2.7 MOTOR LIMIT TIMER

A motor limit timer is provided to take the car to the bottom landing and open the doors if the motor is operating for too long.

#### 4.2.8 VALVE LIMIT TIMER

The same is true for the valves with the down valves being turned off and the doors reenabled if the car is at a floor.

#### 4.2.9 STUCK BUTTON PROTECTION

Stuck button protection is also provided for both car calls and hall calls.

#### 4.2.10 RELEVEL OPERATION

If the car relevels *up* after stopping at the floor, it will respond normally (instantly) the *first* time it relevels up. Any additional up leveling operations after the first one will be *delayed* by a computer-controlled timer (usually 3 seconds). This process will repeat itself every time the car runs to another floor (the first up relevel is always normal, not delayed). Down leveling is always normal and not involved with this timer.

---

# SECTION 5

## THE COMPUTER

---

### 5.0 ABOUT THE PHC SERIES

The computer on the PHC Series elevator controller has been designed for easy communication between the mechanic and the controller and between the controller and other computers or data terminals. The computer will be used (see Figure 5.1) for diagnostic troubleshooting and for programming the controller.

---

### 5.1 THE MC-PCA COMPUTER PANEL - YOUR TOOL FOR PROGRAMMING, DIAGNOSTICS AND DATA COMMUNICATION

Figure 5.1 shows the indicators, switches and terminals on the computer panel.

#### 5.1.1 INDICATORS

**5.1.1.1 COMPUTER ON LIGHT** - When steadily illuminated, this light shows that the computer is functioning normally and completing its program loop successfully. Pressing the COMPUTER RESET button will cause the COMPUTER ON light to turn OFF and the light will stay OFF while the RESET button is depressed. The computer is equipped with an auto reset feature that will cause the computer to reset if, for any reason, the program loop cannot be completed. For example: A very strong electromagnetic field or line noise may interrupt computer functioning. The computer will automatically reset itself and go back to Normal operation. The auto reset feature prevents unnecessary service calls. The auto reset process will also cause the COMPUTER ON light to turn OFF briefly. If the COMPUTER ON light is flashing continuously, it means that the computer board is malfunctioning. Inspect the controller chip (see Figure 5.1) and EPROM chip to see if it is properly seated and to see if the pins are properly inserted into the socket.

**5.1.1.2 VERTICAL STATUS INDICATOR LIGHTS** - These lights show the status of the elevator. Table 5.1 shows a list of these lights and their meanings.

**TABLE 5.1** Status Indicators

LIGHT NAME	MEANING
SAFETY ON	Safety circuit is made.
DOORS LOCKED	Door lock contacts are made.
HIGH SPEED	Elevator is running at high speed.
IND SERVICE	Elevator is on Independent Service.
INSP/ACCESS	Elevator is on Car Top Inspection or Hoistway Access operation.
FIRE SERVICE	Elevator is on Fire Service operation.
TIMED OUT OF SERVICE	Elevator is Timed Out of Service.
MOTOR/VALVE LIMIT TIMER	Motor/Valve Limit Timer has elapsed.

**FIGURE 5.1 MC-PCA Computer Panel Board Layout**

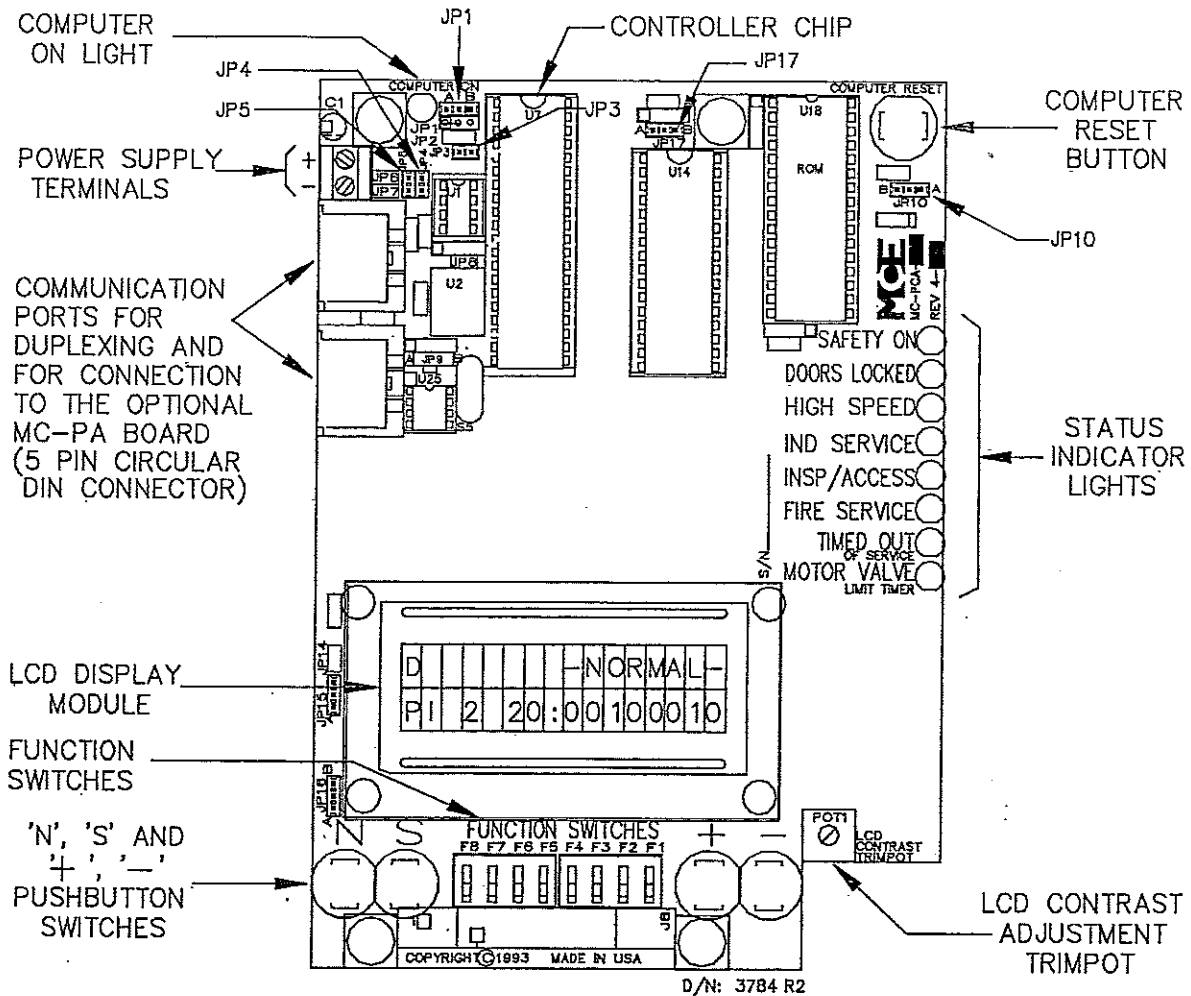

**5.1.1.3 DIAGNOSTICS LCD DISPLAY** - The 32-character LCD (Liquid Crystal Display) displays various information depending on the positions of the F1-F8 switches. Diagnostic mode is accessed when all of the switches are in the down position. The LCD display shows an elevator status message, the car position, the contents of the computer's internal memory and communication status.

**5.1.2 SWITCHES, BUTTONS & ADJUSTMENTS**

**5.1.2.1 COMPUTER RESET PUSHBUTTON** - Pressing the *RESET* button will cause the computer to reset. If the elevator is running, the controller will drop the safety relay and bring the elevator to an immediate stop. The elevator will then go to the terminal landing (or to the next landing if the controller has the absolute floor encoding feature) to correct its position before it can respond to any calls. Existing calls and P.I. information will be lost each time the computer is reset.

**5.1.2.2 N, S, +, & - PUSHBUTTONS** - The pushbuttons allow the mechanic to view and change data in the computer memory. These pushbuttons have different functions depending on the current mode (Diagnostic mode [see Section 5.3], Program mode [see Section 5.4], External Memory mode [see Section 5.5], or System mode [see Section 5.6]).

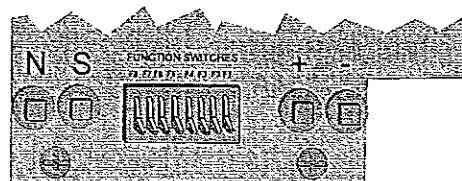

**5.1.2.3 MODE SELECTION F1-F8 FUNCTION SWITCHES** - The computer panel operates in different modes. Diagnostic mode is useful for diagnosing and troubleshooting the elevator system. It is initiated by placing all of the *F1-F8* switches in the down position. Program mode is used to set up the controller to meet the elevator specifications. Program mode is initiated by moving the *F1* switch to the up position (with all other *F* switches in the down position). External Memory mode is initiated by placing the *F2* switch in the up position (with all other *F* switches in the down position) and is useful for diagnosing the elevator system by viewing the computer's external memory. System mode is initiated by placing the *F3* switch in the up position (with all other *F* switches in the down position). Programming System mode functions does not require the car to be on inspection. When only the *F8* switch is placed in the up position, the system status displays are available on the LCD display (see Section 5.1.4).

**5.1.2.4 LCD CONTRAST ADJUSTMENT TRIMPOT** - The contrast on the LCD can be adjusted to make it easier to read by turning this trimpot. See Figure 5.1.

### 5.1.3 TERMINALS

**5.1.3.1 POWER SUPPLY TERMINAL** - The two terminals marked (+) and (-) are for +5VDC and Ground, respectively, to the MC-PCA board. See Figure 5.1.

**5.1.3.2 COMMUNICATION PORT FOR DUPLEXING** - The DIN connector shown in Figure 5.1 is used for high-speed communication between two cars in a duplex configuration. The communication cable is a twisted pair shielded cable. Two wires are for signals and the third is for grounding the shield (see the Job Prints for hook-up details).

**5.1.3.3 COM PORT 1 AND 2** - These terminals are used to connect to a peripheral device (refer to Section 5.4.9.7).

### 5.1.4 STATUS DISPLAYS

To access the Status Displays, place function switch *F8* in the up position (*F1* thru *F7* must be down). Press the *N* pushbutton to cycle through the available status displays.

The following system status displays are available for viewing on the LCD display:

- **PTHC Software Version** - Main processor software version number.
- **Eligibility Map** - Door access for each floor (*F* = front, *R* = rear, *B* = both). Read left to right - floors 1 thru 16 in the top row, floors 17 thru 32 in the bottom row. See Sections 5.4.2.5 and 5.4.2.6 for programming instructions.
- **Current Load** - The current load in the car as a percentage of full load (analog load weigher required).

---

## 5.2 COMPUTER SECURITY

A computer security system is available for the PHC controllers. The system requires the user to enter a passcode before they can adjust the controller's parameters through the computer.

The controllers are shipped without the security system. However, the security system can be purchased through MCE's Technical Support Department. Complete installation instructions are provided with the modification package. The next few paragraphs explain how the security system works after it is installed.





**NOTE:** This message is not related to Computer Security. If this message is seen on the LCD screen, it means that the Passcode Request Option has been activated and that a passcode is required in order to run the elevator on any mode of operation other than Inspection. See Section 5-6.2, Passcode Request Menu for more information.



### 5.2.1 PASSWORD

There are two sections that are secured by an 8-digit, alpha-numeric code chosen by the customer, Program Mode and System Mode.

When either of these two sections is accessed, the LCD display will show:



The password is entered the same way and has the same code.

- N Pushbutton      Change the position of the cursor.
- + Pushbutton      Increment the current position by one.
- Pushbutton      Decrement the current position by one.
- S Pushbutton      Check for a match.

If an invalid code is entered, the operator will be prompted to re-enter the code. Once a valid code has been entered, access is granted to the programming options and the password will not have to be reentered until the Password Timer expires.

## 5.3 DIAGNOSTIC MODE

MCE's PHC Elevator Controller Computer with On-Board Diagnostics is self-sufficient; external devices are not required when using the computer. The computer is generally the most reliable component of the elevator control system and the On-Board Diagnostics was designed to aid in evaluating the status of the control system. Using the On-Board Diagnostics helps to pinpoint the cause of elevator malfunctions.

### 5.3.1 GETTING INTO DIAGNOSTIC MODE

Diagnostic mode is initiated by placing the F1-F8 switches in the down position. A description of the LCD display format and the function of the N, S, +, and - pushbuttons during Diagnostic mode follows.

#### FUNCTION SWITCHES

F8 F7 F6 F5 F4 F3 F2 F1

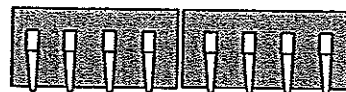

Diagnostic mode

### 5.3.2 FUNCTION OF N PUSHBUTTON

The N pushbutton (see Figure 5.1) allows for the advancement of the computer memory address, which is displayed on the second line of the LCD. For example, for the following display, pressing the N pushbutton once will cause the 2 of the address 20 to begin blinking. By continuing to press the N pushbutton, the 0 of the address 20 will begin to blink. The cycle will continue while the N pushbutton is being pressed. Once the digit



to be changed is blinking, the address can then be modified using the + and – pushbuttons (refer to Sections 5.3.4 and 5.3.5).

The data (8 digits) that corresponds to the memory address is displayed to the right of the address (see Section 5.3.6.4). This display will change as the memory address changes.

### 5.3.3 FUNCTION OF S PUSHBUTTON

The S pushbutton (see Figure 5.1) ends the ability to change the address by stopping the digit from blinking. If the S pushbutton is not pressed, the selected digit will stop blinking automatically after a period of about 20 seconds.

### 5.3.4 FUNCTION OF + PUSHBUTTON

The + pushbutton (see Figure 5.1) modifies the digit of the computer memory address selected by the N pushbutton. If the + pushbutton is pressed, the selected digit is incremented by one. The data display will also change as the address changes. For example, if the 0 of the address 20 is blinking, pressing the + pushbutton once will change the address from 20 to 21. Pressing the + pushbutton several more times will change the address to 22, 23, 24, etc., up to 2F and then back to 20 again. If the 2 of the address 20 is blinking, pressing the + pushbutton once will change the address from 20 to 30. Pressing the + pushbutton several more times will change the address to 40, 50, 60, etc., up to F0. Once the address has reached F0, pressing the + pushbutton will cause the address to begin back at 00.

### 5.3.5 FUNCTION OF – PUSHBUTTON

The – pushbutton (see Figure 5.1) also modifies the digit of the computer memory address selected by the N pushbutton. If the – pushbutton is pressed, the selected digit is decremented by one. The data display will also change as the address changes. For example: If the 0 of address 20 is blinking, pressing the – pushbutton once will change the address from 20 to 2F. Pressing the – pushbutton several more times will change the address to 2E, 2D, 2C, etc., back to 20 again. If the 2 in the address 20 is blinking, pressing the – pushbutton once will change the address from 20 to 10. Pressing the – pushbutton several more times will change the address to 00, F0, E0, etc., back to 00. Once the address has reached 00, pressing the – pushbutton will cause the address to start over at F0.

### 5.3.6 FORMAT OF LCD DISPLAY

The multi-functional alphanumeric LCD display shows the car's status and can also be used for diagnostic purposes to display the contents of the computer's memory. The figure shows the various parts of the LCD in Diagnostic mode.

5.3.6.1 For simplex controllers, the letter D in the drawing will not appear on the LCD and instead that part of the display will always be blank. For a duplex controller, this part of the display provides information about the communication between the controllers and about the dispatching. One of the following codes should appear:

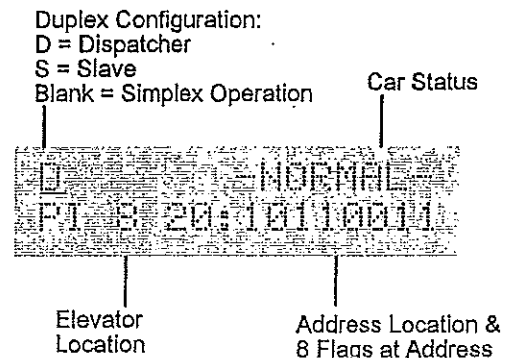

**S** Indicates that this computer is acting as the slave to the dispatching computer. Hall call assignments are received from the dispatching computer through the communication cable.

**D** Indicates that this computer is acting as the dispatcher. It is responsible for assigning hall calls to itself and to the other controller.

**BLANK** If this part of the display is blank, it denotes that communication has not been established between the two cars (see Section 6 for information on identifying and solving communication problems).

**5.3.6.2 STATUS MESSAGE** - This part of the LCD shows the prevailing status of the elevator. There is a status message for each special operation (e.g., Fire Service). There are also status messages for several different error conditions (e.g., open safety string). See Table 5.2 for a complete list of these status messages and their meanings.



**TABLE 5.2 Error Status Messages and Response Chart**

MESSAGE	MEANING	PROBABLE CAUSE	NEEDED RESPONSE
ATT SVCE	The car is on attendant operation	The attendant service input (ATS) is activated.	Go into program mode and check to see if any spare inputs are programmed as ATS. Then check to see if that particular input is activated.
BFD/TFD	Bottom Floor Demand or Top Floor Demand.	The controller is trying to establish the position of the car by sending it to either the top or the bottom. Usually associated with bottom floor demand. Bottom Floor Demand has four possible causes: 1. A change from Inspection to Automatic operation. 2. Pressing the COMPUTER RESET button. 3. Initial Power-up. 4. If the car is at the top floor, and the controller gets an up slow down signal (USD), the controller will create a Bottom Floor Demand.	Bottom Floor Demand should be cleared when all of the following conditions are met: 1. The car is at the bottom and the down slow down (DSD) input to the controller is OFF (because the switch should be open). 2. The Door Zone (DZ) input to the controller is ON. 3. The Door Lock (DLK) input to the controller is ON. If the car is at the bottom, and the message still flashes, check the Down Slow Down switch & associated wiring. Also, inspect the door zone landing system vane or magnet at the bottom floor and the door lock circuit.  Top Floor Demand should be cleared when all of the following conditions are met: 1. The car is at the top and the up slow down (USD) input to the controller is OFF (because the switch should be open). 2. The Door Zone (DZ) input to the controller is ON. 3. The Door Lock (DLK) input to the controller is ON. If the car is at the top, and the message still flashes, inspect the Up Slow Down Switch & associated wiring. Also, inspect the door zone landing system vane or magnet at the top floor and the door lock circuit.  NOTE: If the controller has the absolute floor encoding feature, then the Bottom and Top Floor Demands should be cleared when the car stops in any door zone. The car does not have to travel to the top or bottom.
CALL BUS	Both the Car Call Bus and Hall Call bus are disconnected.	A problem in the wiring or fuses. There is no power to the call circuits on the HC-CIO and HC-PCIO board(s).	Check the Call Bus fuses. Check the wires that go to the Call Power inputs on the HC-PCIO & HC-CIO board(s) in the controller.
CAPTURE	Capture test function active	CTST input has been activated.	Go into Program mode. Check the spare inputs to see if any are programmed as CTST. Ensure that this input is NOT activated.
CAR SAFT	Car safety device activated	One of the car safety devices has activated, opening the safety circuit (e.g., emergency exit contact, safety clamp switch, car-top emergency stop switch).	Check all car safety devices. Refer to controller wiring prints for applicable devices.
CC BUS	The Car Call Bus is disconnected.	A problem in the wiring or fuses. There is no power to the Car Call circuits on the HC-CIO and HC-PCIO board(s).	Check the Car Call Bus fuse. Check the wires that go to the Car Call Power inputs on the HC-PCIO & HC-CIO board(s) in the controller.
CNFG ERR	Configuration Error.	Incorrect Programmed value(s), e.g., a floor selected for the fire floor is not one at which the elevator stops.	Go into Program Mode. Check all of the values associated with stops & special floors. Save the values. If the message still appears, contact MCE.